

Tekniske data for Aluminiumsskap Enkelvegget

Denne skapserien er konstruert for utendørs bruk og har innvendige festebraketter lik Finelcomps andre tavlesystemer. Skapene er pulverlakkert lys grå med lett struktur i overflaten. Skapene egner seg svært godt i korrosjonsutsatte områder, f.eks. langs veier og/eller kystnære områder.

Montasjeplate, innredning og sokkel bestilles/monteres separat. Ta kontakt for å få tegnet innredning tilpasset ditt behov.

Tekniske Data

IP-grad	IP55
Slagfasthet	IK10
Farge	RAL6012 Grønnsvart
Materiale	AW5754 Saltvannsbestandig Aluminium



Artikkel	Navn
CV081689	Aluminiumsskap enkelvegget H980 B650 D380 RAL6012
CV081696	Aluminiumsskap enkelvegget H980 B800 D380 RAL6012
CV081702	Aluminiumsskap enkelvegget H1120 B800 D380 RAL6012
CV081719	Aluminiumsskap enkelvegget base B650 RAL6012
CV081726	Aluminiumsskap enkelveggetbase B800 RAL6012

*Mål er avrundet, mindre produksjonsavvik må forventes. Bredde på skap er uten veggfester. Skap har dybde ca. 400mm fra bakkant til dør. Dybde bakkant til hendel er ca. 424mm. Dybden på hatt er ca. 413mm.

Montasjeveiledning

Det er ikke prefabrikkerte hull i skapet og hulltaking må gjøres ved bruk av lokkeverktøy eller hullsag. Egnede M/PG-nipler eller flenser benyttes. Kondensnippel bør monteres ved utendørs bruk.

Veggmontering

Veggskap festes til vegg med de fire medfølgende veggbrakettene. Veggbrakett skal være helt plan med skap og vegg når skruene festes. Skapet skal festes ved å benytte fire stk veggbraketter.

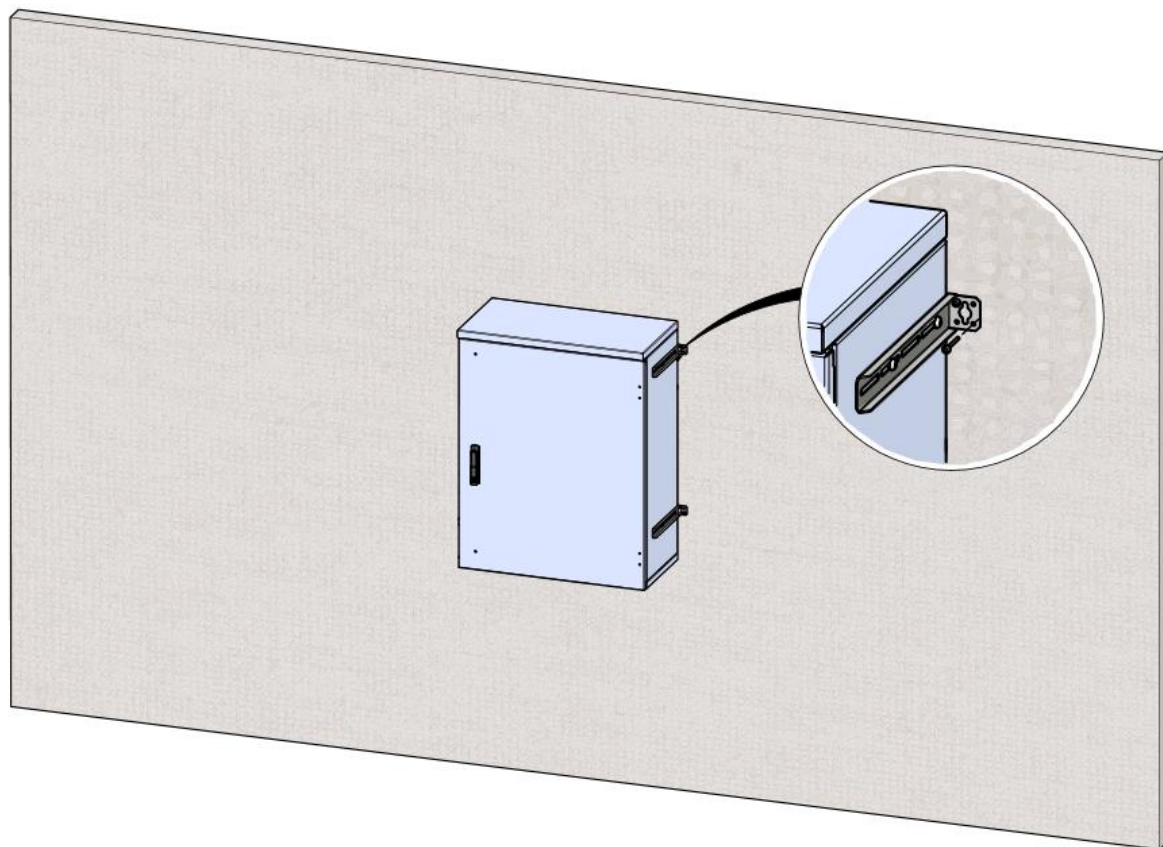

Montasje på sokkel

Lokaliser de 4 forhåndsmerkede punktene på innsiden av skap. Forhåndsmerkingen kan kontrolleres mot dimensjonene på hullbildet til sokkel slik at det er sikkert at riktige punkter er funnet. Bor 4stk Ø8 hull gjennom bunnplaten på skapet.

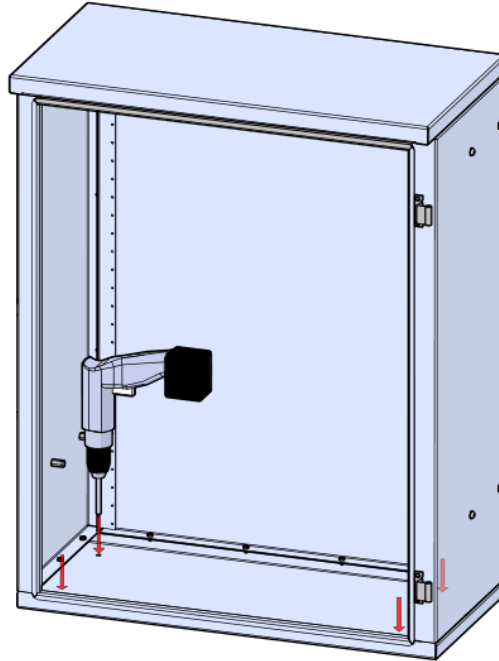

Fest skapet til sokkel iht. illustrasjon under. Skap festes med skivene og boltene som medfølger sokkel.

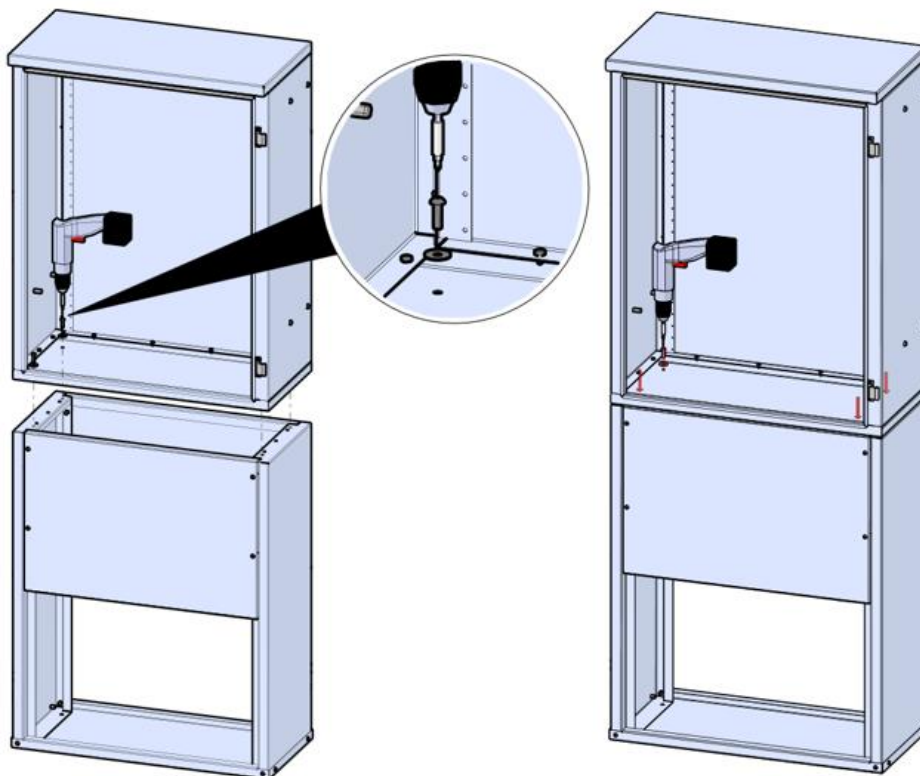

Ferdig planert bakkenivå bør overlappe frontdeksel på sokkel slik at kabelføring ikke er synlig. Det anbefales å komprimere massene rundt sokkel godt for å sikre best mulig stabilitet. Kabler føres gjennom hull i toppen av sokkel og inn gjennom nipler/flenser i bunnen av skapet.

Sokkel og veggfeste

For god stabilitet bør skap festes til vegg der det er mulig selv om sokkel er benyttet.

Følg stegene over for montasje av sokkel. Sett deretter skap og sokkel på plass mot stabilt underlag og følg stegene over for feste av skap til vegg. Ferdig planert bakkenivå bør være i overkant av frontdeksel på sokkel.

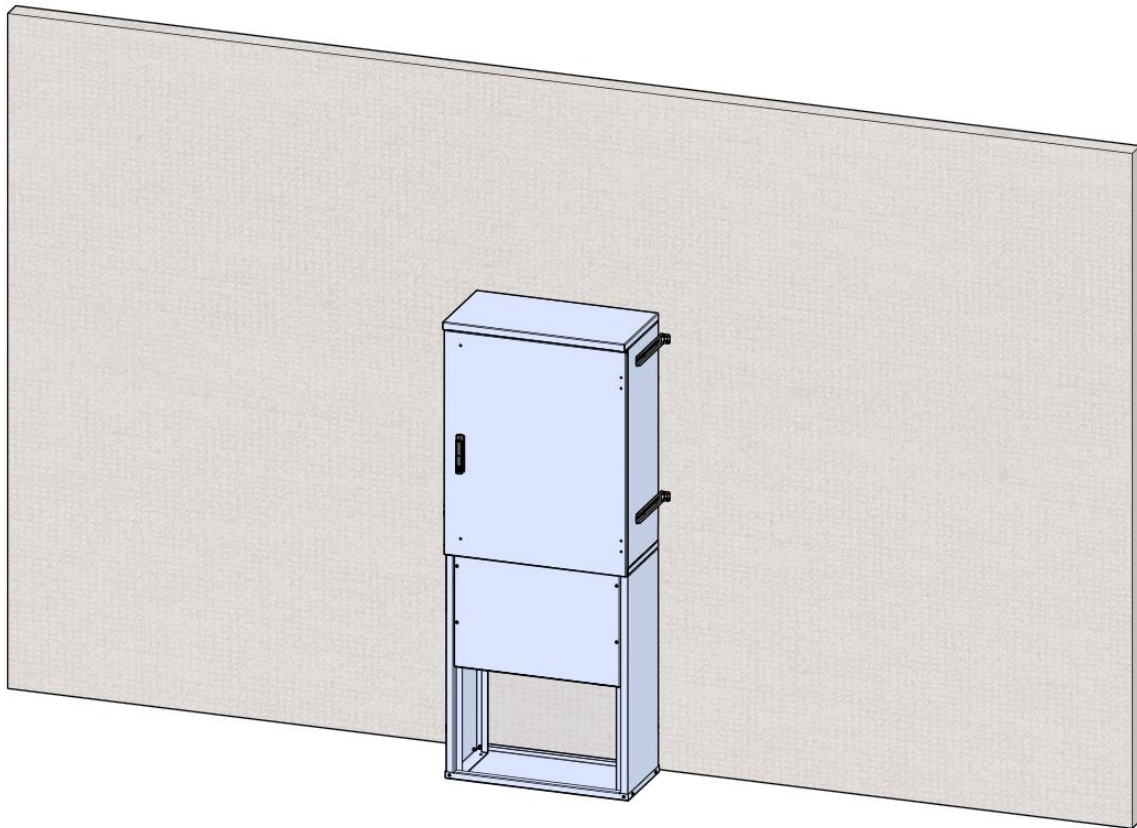

ASSEMBLY INSTRUCTIONS AND PART LIST



F SERIE

IP20–IP55 ENCLOSURES
AND CELL CENTRES

Finelcomp oy
Yrittäjänkatu 6, PL 68
83501 Outokumpu
FINLAND

Phone +358 13-562 411
Fax. +358 13-555 382

sales@finelcomp.fi
firstname.lastname@finelcomp.fi

WWW.FINELCOMP.FI

F-SERIE: ENCLOSURES AND CELL CENTRES

The components of this most diverse system in the market can be assembled into numerous combinations from small-scale electric outlet enclosures to L- and U-shaped industrial distribution boards.

F-series is available in two parallel versions: F and F NBS, which are nearly identical apart from the base structure. In the F NBS system, the side panels can be installed last after the cabinet has been furnished and cabled.

The enclosure structure can consist either of one section only, or of several modules and spaces. The cell centre can be constructed L- or even U-shaped, as required or as the available space allows. Bus bars are installed at the back of the centre. The aluminium or copper bus bars can be installed at any height.

Most frame parts have been provided with pre-punched holes, which makes protective grounding easy. Doors are grounded through the frame structure via hinges and screws. Screen-protected structures can be built on two levels with either plastic or metal partition covers and two alternative door solutions.

F-SERIE ASSEMBLY INSTRUCTIONS AND PART LIST

1	GENERAL	4
2	ASSEMBLY INSTRUCTIONS	5
	2.1 Base	6
	2.2 Frame plates and end supports	7
	2.3 Back and end plates	8
	2.4 Busbar insulators	9
	2.5 Side plates and front profiles	11
	2.6 Mounting plates and feedthrough beads, and busbar protection covers	12
	2.7 Dividers	13
	2.8 Drip covers and intermediate horizontal profiles	14
	2.9 Mounting heavy components	14
	2.10 Doors	15
	2.11 Corner cell and other special parts	15
3	SEALING	18
	3.1 Degrees of protection	18
	3.2 Sealing of cell centre parts	18
4	BUSBARS	20
	4.1 Constructing of busbar system and grouping of phases	20
	4.2 Horizontal busbars	21
	4.3 Vertical busbars	21
	4.4 Equipment earthing	21
	4.4.1 Protective earthing of frame	21
	4.4.2 Protective earthing of covers and doors	22
	4.5 Connecting of busbars	22
	4.6 Arc protection	24
5	LIFTING AND TRANSPORTING	25
	5.1 Transport break	25
	5.2 Lifting	26
6	OTHER INFORMATION	27
7	TECHNICAL DATA	28
8	ENCLOSURE ASSEMBLY INSTRUCTIONS	30
	8.1 Base	30
	8.2 Enclosure assembly	31
	8.3 Assembly of the group	34
	8.4 Busbar insulator holders and busbar insulators	35
	8.5 Doors	36
	8.6 Intermediate cover system	36
	8.7 Covers, installation rails and spacers	39
	8.8 Touch and finger screens	41
	8.9 Cover door system	42
	8.10 Special parts	43
9	SEALING ENCLOSURE	45
	9.1 IP rating	45
	9.2 Sealing of cell centre parts	46
10	BUSBARS	47
	10.1 Horizontal busbars	47
	10.2 Vertical busbars	48
	10.3 Equipment earthing	48
	10.3.1 Protective earthing of frame	48
	10.3.2 Protective earthing of covers and doors	49
	10.4 Connecting of busbars	49
11	OTHER INFORMATION	51
12	TECHNICAL DATA	52
1.	ENCLOSURE STRUCTURE	53
	1.1 BASE COMPONENTS	53
	1.2 BOTTOM PLATES	55
	1.3 SIDE PLATES	56
	1.4. EXTENSION SIDE PLATES	57
	1.5. END PLATES	57
	1.6. FRONT- AND BACK PROFILES	60
	1.7 END- AND INTERMEDIATE SUPPORTS, HORIZONTAL	61
	1.8 BUSBAR INSULATORS AND BUSBAR INSULATOR HOLDERS	62
	1.9. SPECIAL PARTS	63
2.	CELL STRUCTURE	64
	2.1 BASE COMPONENTS	64
	2.2. FRAME PLATES, DIVIDER AND BACK PLATES	65
	2.3. SIDE- AND END PLATES	67
	2.4. ROOF PLATES AND BUSBAR PROTECTIVE COVERS	69
	2.5. LIFTING COMPONENTS	70
	2.6. HEAVY COMPONENT'S FASTENING	70
	2.7. DRIP COVER PLATE, METAL	71
	2.8. PARTS FOR TRANSPORTATION BREAK	71
	2.9. BUSBAR INSULATORS AND -HOLDERS	72
	2.10. CORNER CELL STRUCTURE	73
	2.11. DRIP COVER PLATE, METAL	74

1 GENERAL

The F-serie is an enclosure system for low-voltage switchgear and controlgear assemblies, primarily intended distribution, control, and automation centres to protect the equipment against mechanical impact, foreign material, dust, and humidity in indoor and outdoor installations. The enclosure also protects users from getting into contact with live components or current conductors.

The F-serie system is type tested and certified according to the Standards IEC/EN 61439 and IEC/EN 62208.

The F-serie cell centre system is modular in two dimensions, i.e. width and height. Table 1.1 shows the modular sizes of the F-serie cell centre system.

The system is assembled using screws, either 4.8*9.5mm plate screws or self-tapping M5*10mm screws.

The technical data of F-serie cell centres are shown in a table in Chapter 7.

In the depth direction, F-serie cell centres are divided into component and busbar compartments. The nominal depths of the compartments are: components 250 mm and busbars 260 mm. Fig. 1.1 shows a cross-sectional view of an F-serie cell centre with nominal dimensions.

Widths [mm]	200, 300, 450, 600 ja 750
Depths [mm]	510 mm (250+260 mm)
Heights [mm]	140, 280, 420, 560, 70, 840, 980, 1120, 1400, 1680 ja 1960
Frame heights [mm]	1680 ja 1960

Table 1.1 Modular sizes of the F-serie cell centre system

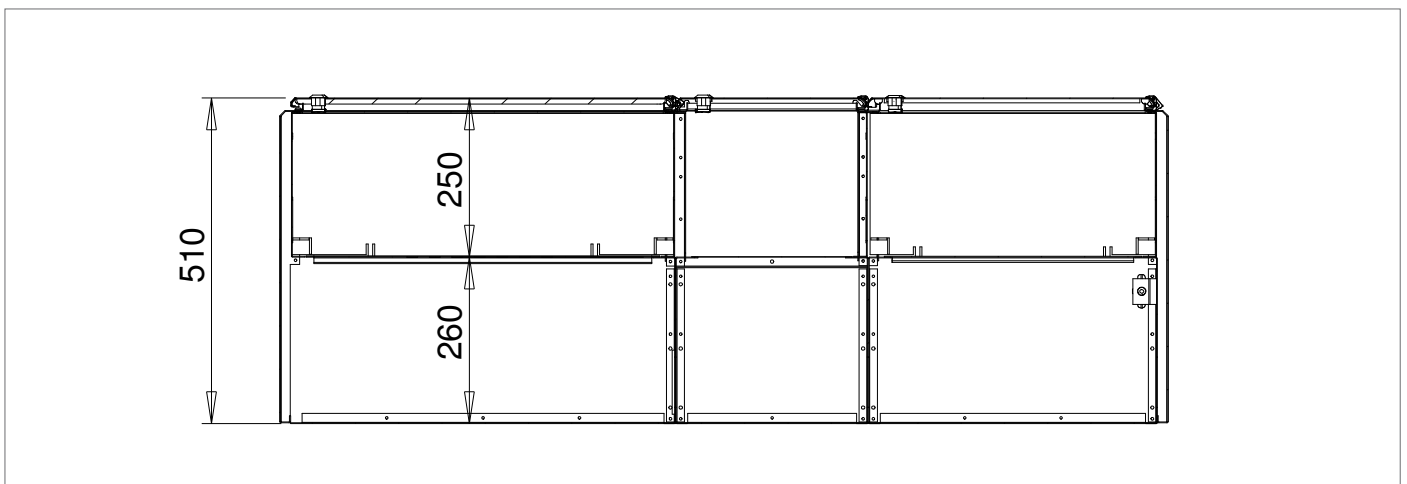

Fig. 1.1 Cross-sectional view of F-serie cell centre. Cell centres are in the depth direction divided into component and busbar compartments.

2 ASSEMBLY INSTRUCTIONS

The assembly of an F-serie cell centre is started with the base, to which the frame, back, and side plates are then fastened. The horizontal and vertical busbar systems are assembled in the frame plate assembly, after which the end supports, the end and side plates and the front profiles are installed.

In the vertical direction, the space is divided into cells using horizontal intermediate profiles and either metallic or plastic drip cover plates. The components are

installed to mounting plates that are installed into the spaces delimited by horizontal intermediate profiles and drip cover plates. Besides the mounting plate, a feedthrough bead is installed into the space as necessary.

F-serie cell centres are assembled using either plate screws or self-tapping screws. Raising beads are fastened using screws and nuts. Table 2.1 shows the screws used in the F-serie system.

Screw	Application
50059054 Plate screw DIN7981 4,8*9,5 or	Assembly of base, frame plates, ends, side plates, mounting plates etc.
50059052 Assembly screw M5*10	
50059053 Hinge screw M5*8 Taptite	For fastening doors to front profiles/side plates
50059055 Plate screw 5,5*13 DIN7981	For fastening insulator holders to frame plate
50059051 Plate screw 5,5*25 DIN7981	For fastening insulator holders and insulator ends to frame plate
Lifting loop screw DIN580 M12	Lifting, fastened to lifting bracket
50059069 Plate screw 4,8*25mm	For fastening end insulator holders
Hex head screw M8*20 DIN933+nut DIN934	For fastening lifting bracket to frame plate

Table 2.1 *The assembly screws used in the F-serie cell centre system.*

2.1 Base

There are two base heights for the F-serie cell centres: 40 mm and 140 mm. Assembly of base is started by fastening the back (3) and front (4) plates to the base ends (1) and dividers (2). Then the base bottom plate (5) is fastened in place, see Fig. 2.1.

The fully assembled base line (1) should be fastened to a separate wooden base frame (2) made of, for instance, 50*100 mm timber according to Fig. 2.2, and using base fastening brackets (3).

- 1. Base end (50028070)
- 2. Base divider (50028071)
- 3. Base back plate (50028042)
- 4. Base front plate (50528067)
- 5. Base bottom plate (50028047)

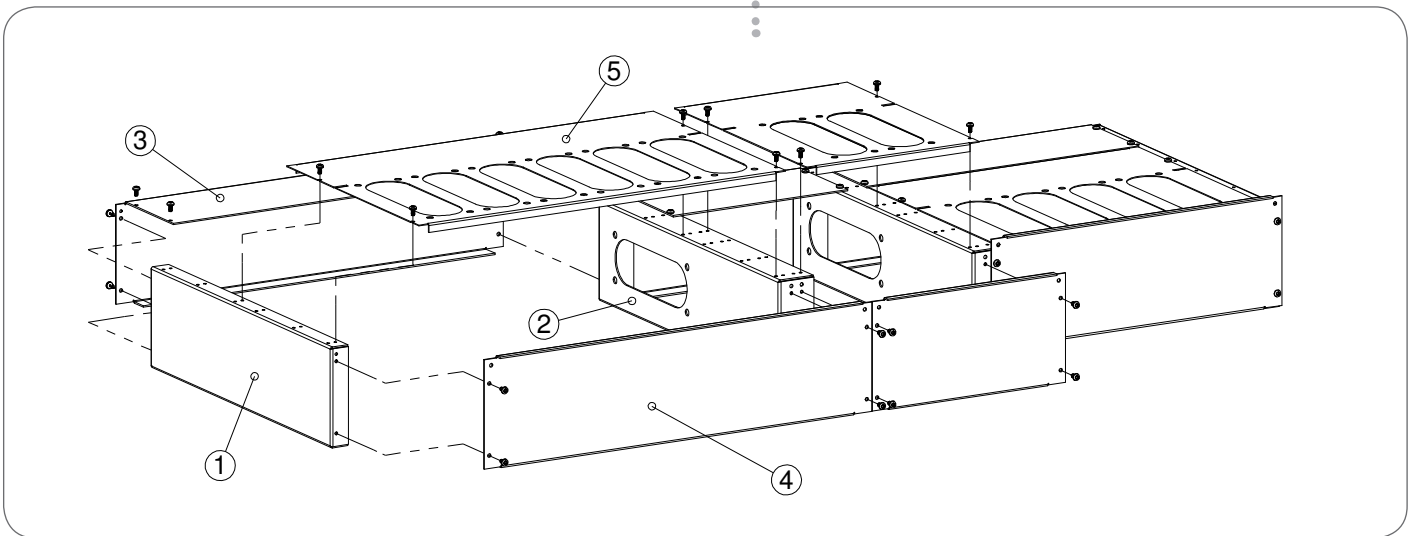

Fig. 2.1 Assembling F-serie cell centre base. The base is assembled to form a line according to the sections.

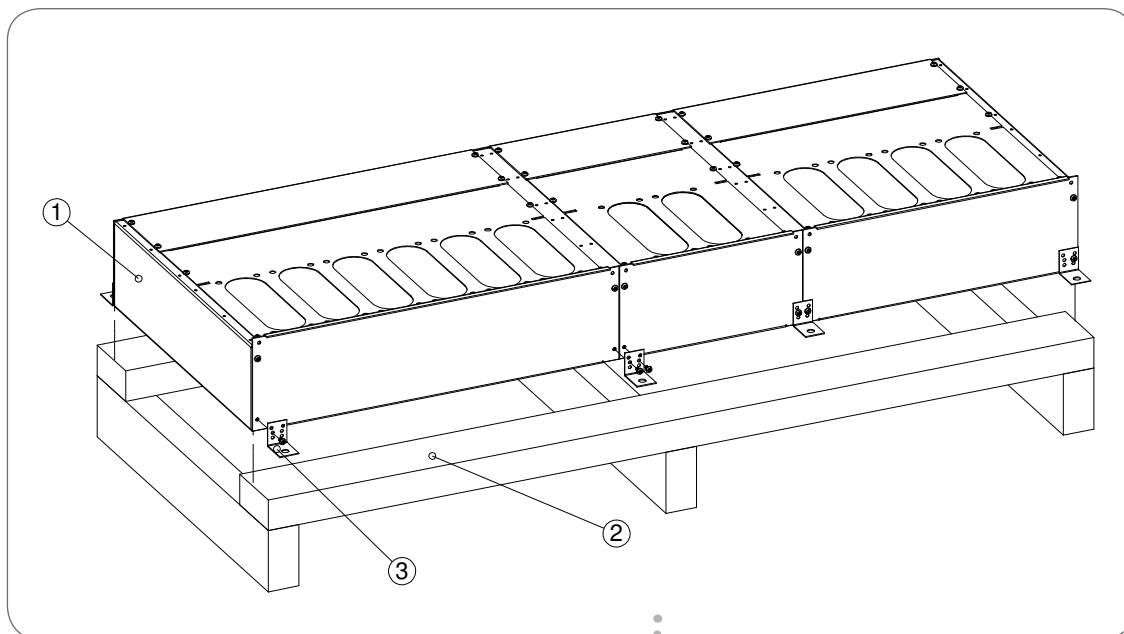

Fig. 2.2 Base and wooden base frame. The base (1) is fastened to the wooden base frame (2) using base fastening brackets (3).

- 1. Base line
- 2. Wooden base frame
- 3. Base fastening bracket (50059001)

2.2 Frame plates and end supports

Before fastening the frame plates to the base it is easier to install the busbar insulator holders to the frame plates on an assembly table, for instance. After possibly installing the insulator holders, the fully assembled frame plate packages are fastened with screws to the base dividers, and single frame plates to the base ends. The frame plates can be fastened together using either screws or, for instance, 4.2 mm pop rivets. End supports are also fastened to the top and bottom of frame plate pairs. Fastening of the frame plates to the base is shown in Fig. 2.3.

It is advisable to fasten the lifting brackets (1) to the frame plates before fastening the roof plates. Each lifting bracket is fastened to the frame plate using four hex. head M8 screws. Knock out the blanks on the cell end plate and drill 13 mm holes in the F-series system end plates for the lifting eyes. Fig. 2.4 shows the fastening of lifting bracket and lifting eye to the frame structure.

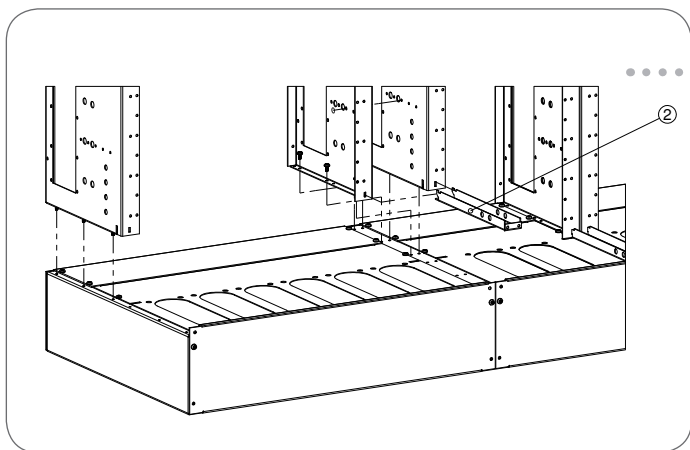
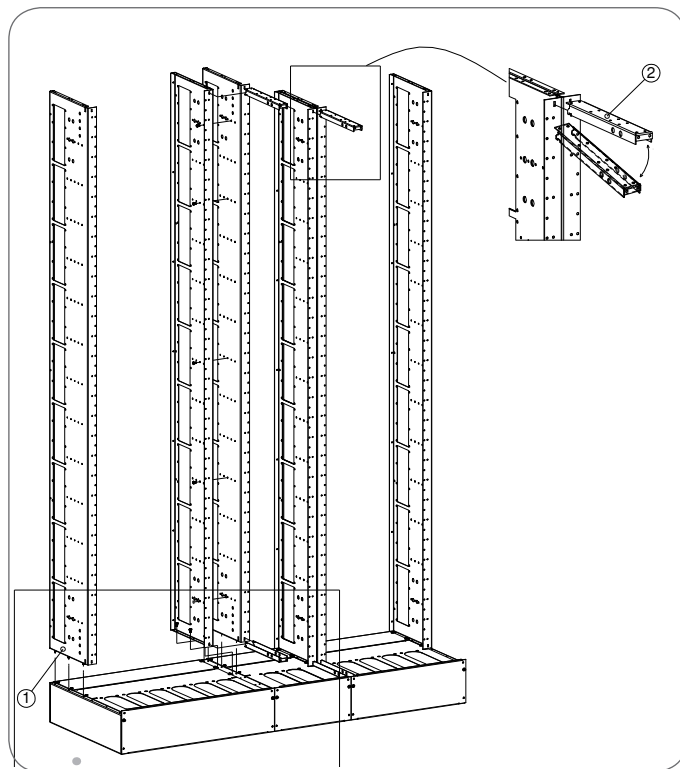
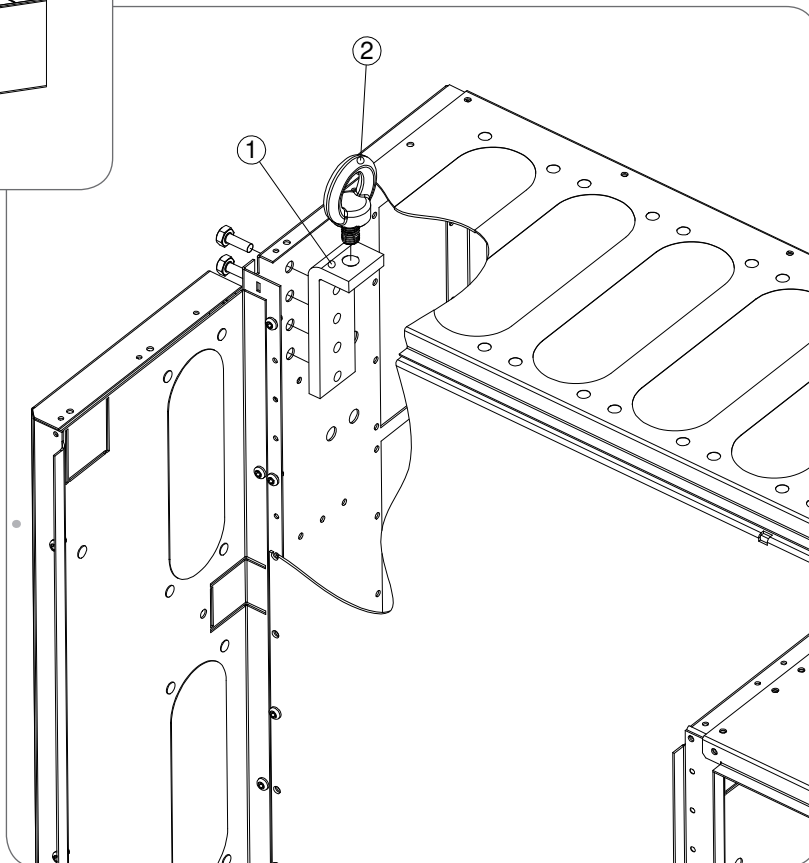

Fig. 2.3 Fastening frame plates (1) and frame plate packages to base. Frame plate packages are screwed or riveted together, the end supports are installed, and the assemblies are then fastened to the base dividers.

1. Side plate for cell 50-196 (50028001)
2. End support 25 (50026032)



1. Lifting bracket (50028095)
2. Lifting loop M12 (50028094)

Fig. 2.4 Fasten lifting brackets (1) to frame plates using M8 screws. Drill holes to the end plate for the lifting loop M12 (2), or remove the knock-out blanks.

2.3 Back and end plates

After having set up the frame plates, the frame of the F-serie cell centre is straightened by fastening either the back plates to the rear part of the frame plates or sufficiently large mounting plates to the front part of the frame plates. Before fastening the rear plates you should install possible sealing strips to the frame structure. At the top, the frame plates are connected together using end plates. Figure 2.5 shows the installation of back and end plates to the frame structure.

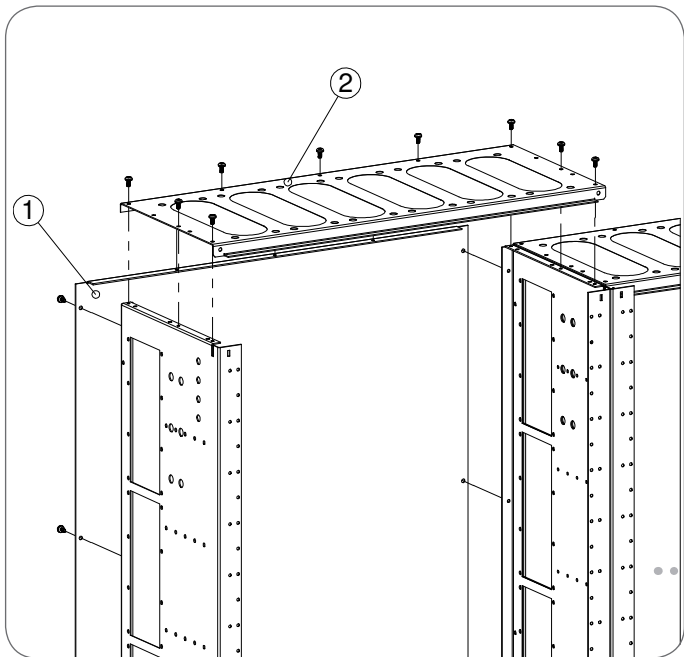
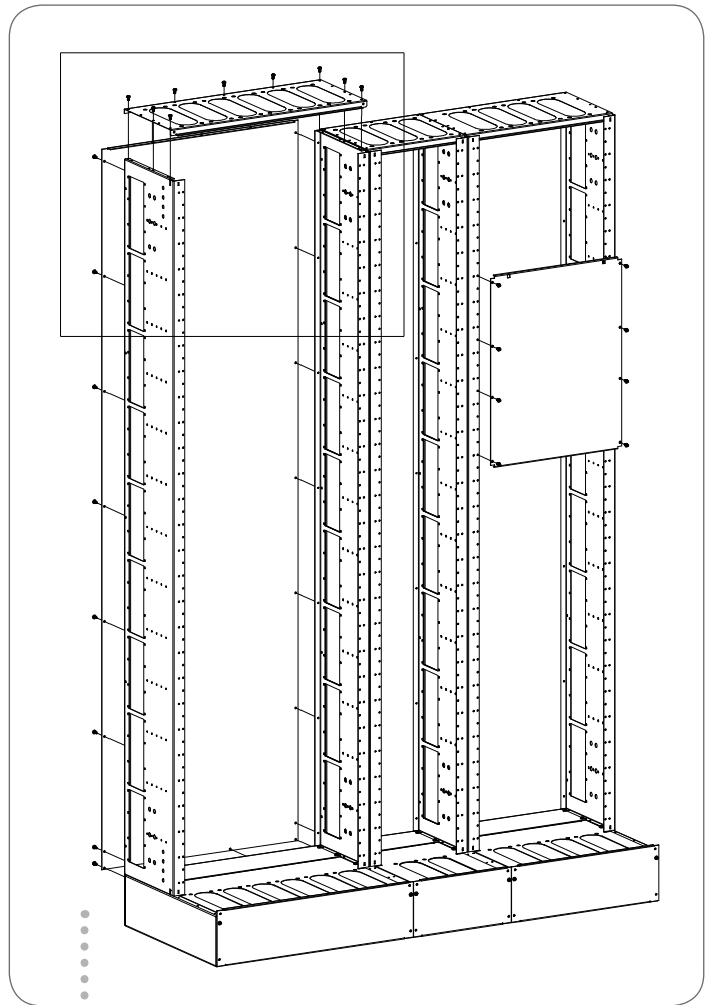

Fig. 2.5 The back (1) and end plates (2) straighten the frame structure of the cell centre. The frame can also be straightened using mounting plates.

For the top of the cell centre you can use either two 250 mm deep F-serie system end plates or a single cell end plate per section, see Fig. 2.6.

- 1. Kennon End plate (50528161-2)
- 2. End plate 45-25

Fig. 2.6 Top cover alternatives of the F-serie system. The top cover can be made using either a single, full-depth end plate or two 250 mm deep end plates (2).



- 1. Back plate 60-196 (50028012)
- 2. End plate 60-25 6C (50523026-2)

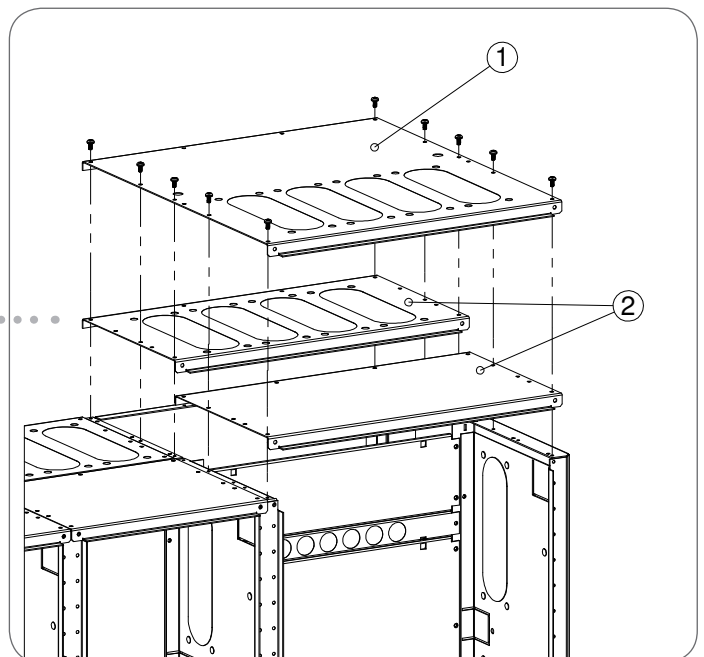

2.4 Busbar insulators

The busbar insulators can be fastened to the frame plates either before the frame plates are mounted to the base or after mounting the frame plates, as shown in Fig. 2.7.

Busbar insulator holders (1 and 3) and busbar insulator ends (2) for both horizontal and vertical busbars are installed to suitable positions on the frame plate. Vertical busbar holders (4) corresponding to the section width are installed to the frame plates. Vertical busbar ends (5) are installed to the ends of vertical busbars.

The maximum distance between busbar insulators in the F-serie system is 450 mm and, therefore, section widths exceeding 450 mm require the use of intermediate busbar insulators. For vertical busbars the maximum distance between insulator holders fastened to frame plates is 450 mm.

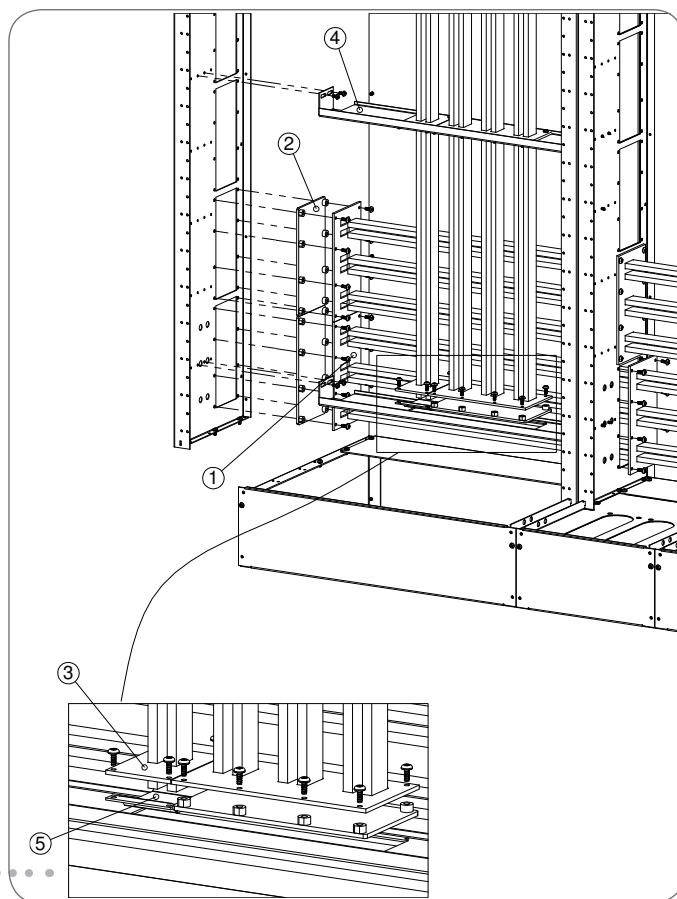

Fig. 2.7 Fastening busbar insulators and vertical busbar holders to frame plates. Intermediate busbar insulators must be added to structures with section widths of 600 mm or greater.

1. Busbar insulator MFBH H30 (6) 10*30 (50081012)
2. Busbar insulator end MFEBH 210, 100*210 (50081052)
3. Busbar insulator MFBH h30 10*30 (2) (50081002)
4. Vertical busbar holder 60 (50028052)
5. Busbar insulator end MFEBH 70, 70*100 (50081050)

Fastening horizontal busbar insulators

Horizontal busbar insulators are fastened with the bigger insulating gap towards the rear of the cell centre (insulators for 10x50 busbars are symmetrical).

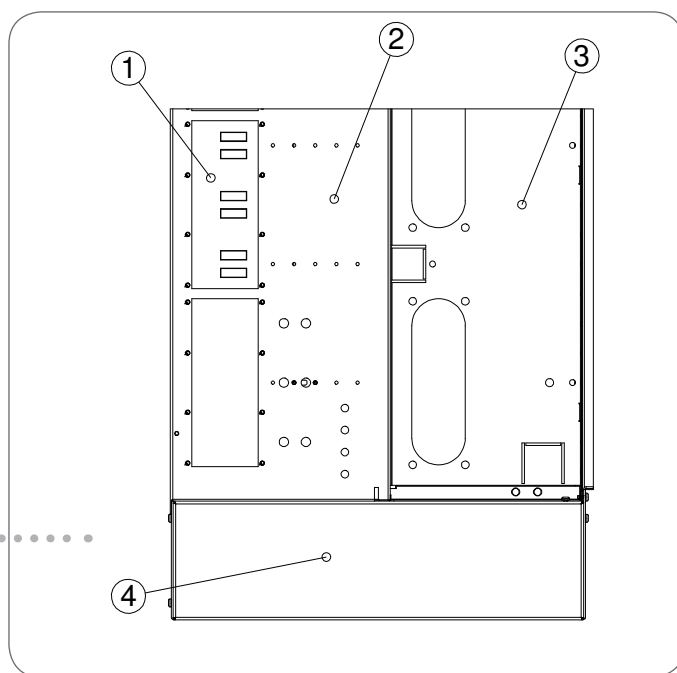

Fig. 2.8 Installing horizontal busbar insulators. The busbar insulator (1) is fastened to the frame plate (2) with screws.

1. Kute - busbar insulator
2. Frame plate
3. Front divider
4. Base

Fastening vertical busbar insulator holder and insulator

The vertical busbar holders (4) are fastened to the frame plates (1) as described above. Figure 2.9 shows the fastening of vertical busbar holders (4) and insulators (2) to the frame structure.



- 1. Frame plates
- 2. Busbar insulators
- 3. Vertical busbar holder
- 4. Front dividers
- 5. Front profiles

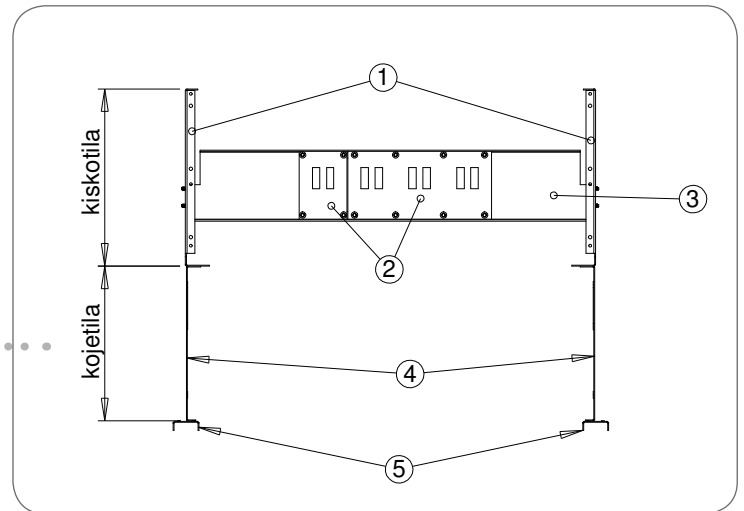

Fig. 2.9 Installing vertical busbar holder and insulator to frame plates.

Fastening insulator ends

Install insulator ends (3) to the end of busbars (1). The insulator ends are fastened together with the busbar insulators (2) to the inside of the frame plate (4) using 5.5x25 mm plate screws (5), see Fig. 2.10.



- 1. Busbar
- 2. Kute - busbar insulator
- 3. Busbar insulator end MFEBH 70, 70*100 (50081050)
- 4. Frame plate
- 5. Plate screw 5,5*25 (50059051)

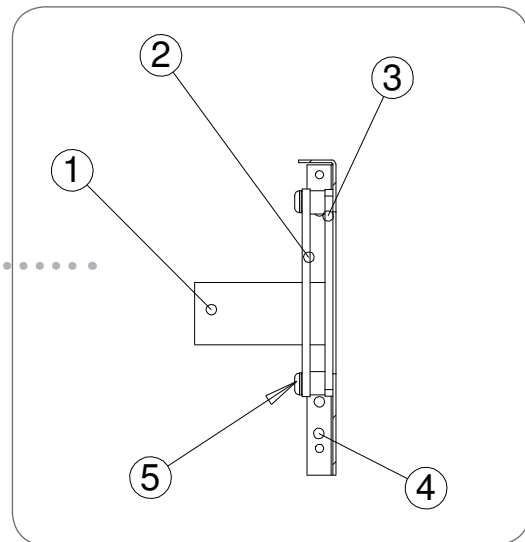

Fig. 2.10 Fastening insulator ends.

2.5 Side plates and front profiles

With the main frame assembled, i.e. the frame, end and rear plates as well as the busbar insulators, the rest of the end plates, side plates and front profiles are fastened to the frame structure, see Fig. 2.11.

The side plates (1) are fastened from their rear and top sides with screws to the frame plates (2) at the ends of the cell centre structure. The end plates (3) are fastened to the front part of the main frame, the component space, and to the top of the end supports and side plates. The front profile is fastened with screws at the bottom to the base (and the end support) and at the top to the end plate and the end support. At the bottom M5 nuts and screws can be used.

-
1. Side plate 50-196 for cell centre (50528001-2)
 2. Frame plates
 3. End plates
 4. Front profiles

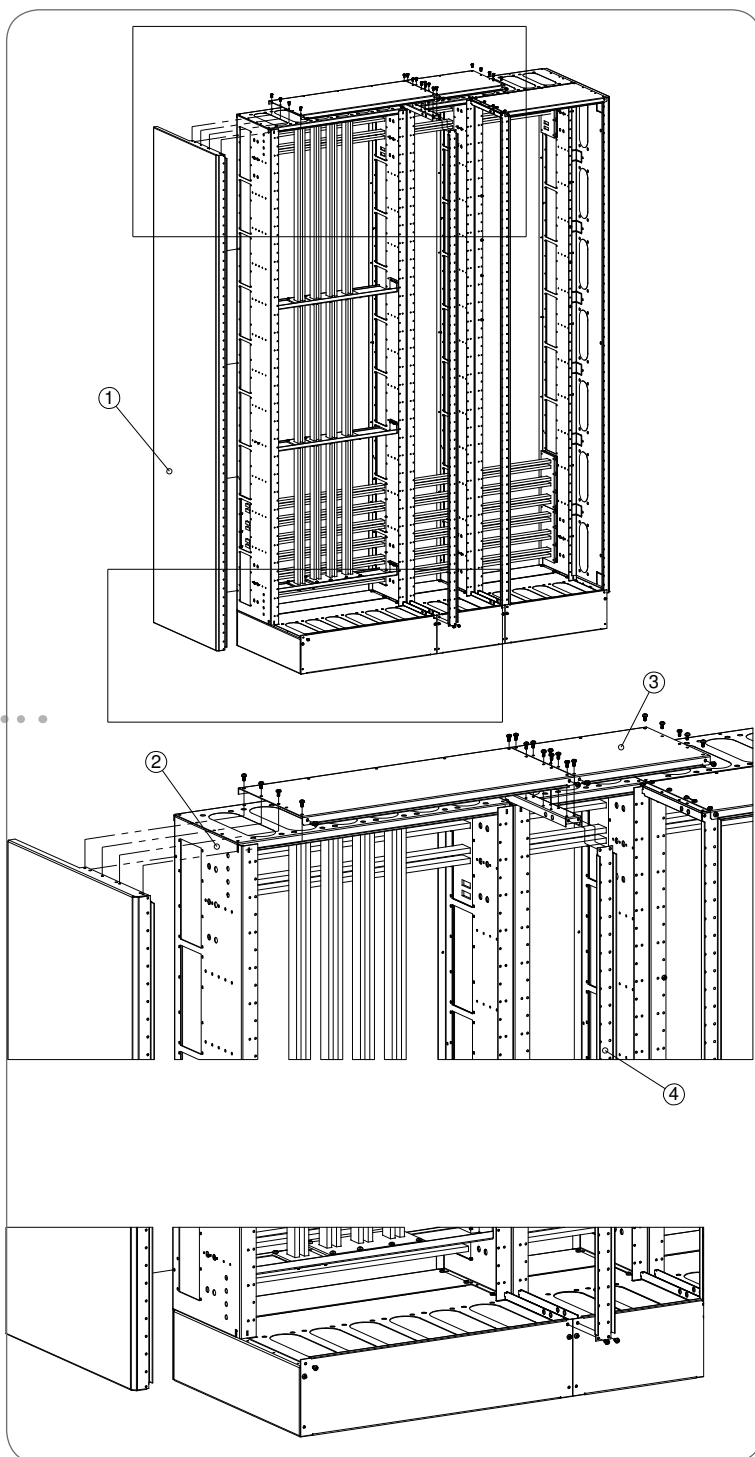

Fig. 2.11 Fastening side (1) and end plates (3) and front profiles (4) to the frame structure.

2.6 Mounting plates and feedthrough beads, and busbar protection covers

Mounting plates are used as the mounting base for electrical and mechanical components. In the cable field, the mounting plates can also be used for protecting the busbars against touching.

The mounting plates (1) are fastened with screws to the front mounting flanges of the frame plates. If necessary, feedthrough beads (2) can be installed above or below mounting plates for feeding through cables and to prevent the spreading of arc possibly ignited in the busbar section of the centre, see Fig. 2.12.

Busbar protection covers (1) provide touch screening for possible busbars running through the cable section. The busbar protection covers are fastened in the same way as the mounting plates, see Fig. 2.13.

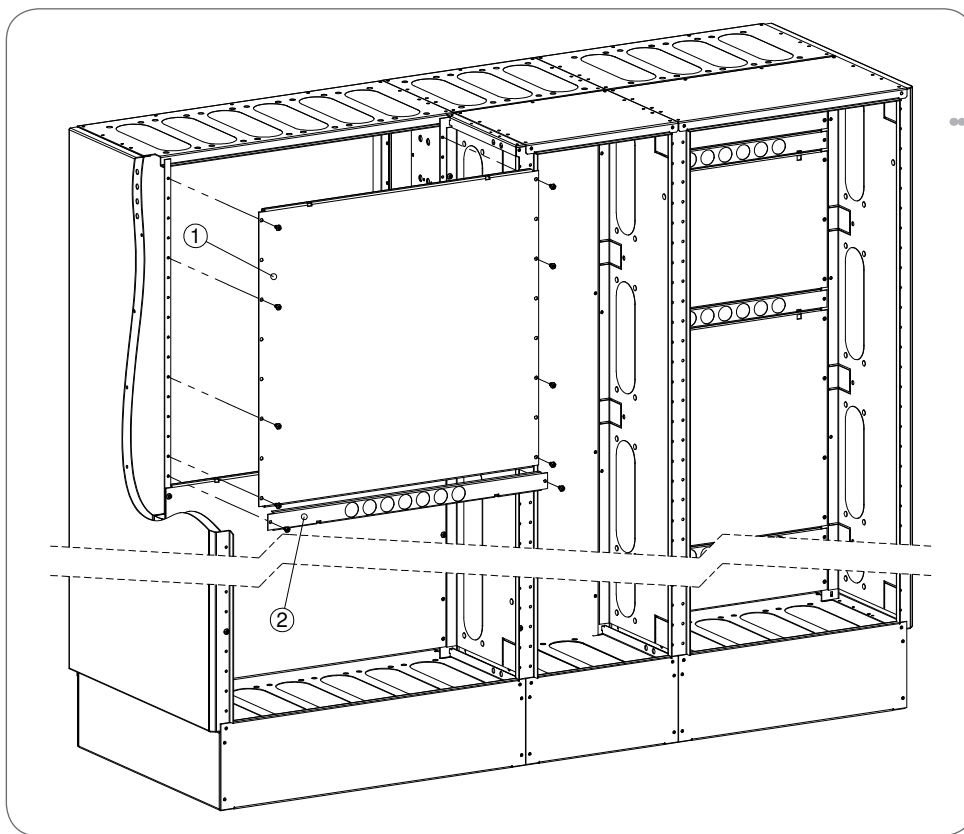
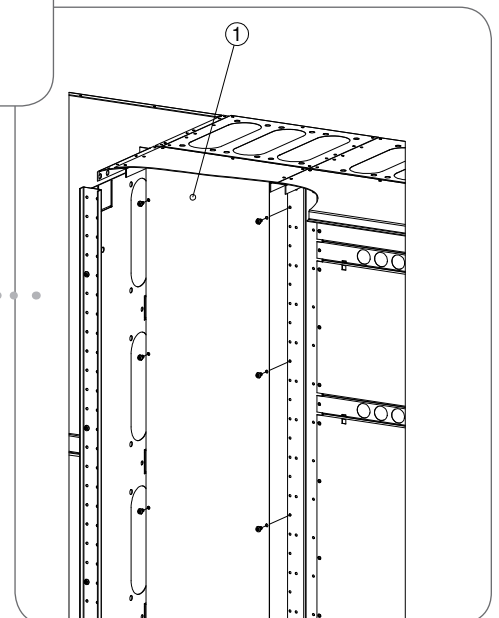

Fig. 2.12. Fastening mounting plates and feedthrough beads to frame structure. Feedthrough beads restrict the spreading of arc from busbar space to component space in the cell centre.

- 1. Mounting plate 60-56 (50027093)
- 2. Feedthrough bead 60 (50028113)

- 1. Busbar protective cover 30-98 (50028031)

Fig. 2.13 Busbar protection cover is used as touch screen for busbars running through cable section.



2.7 Dividers

Dividers are used for vertically delimiting and separating two fields. The C flanges placed 280 mm apart on the dividers can be used for feeding through output cables, for example. There are also dividers with 140 mm blank spacing, as well as solid, unperforated dividers.

The dividers are fastened to the frame plates at the back and to the front profiles or side plates at the front, see Fig. 2.14. At the cell centre ends, no dividers are

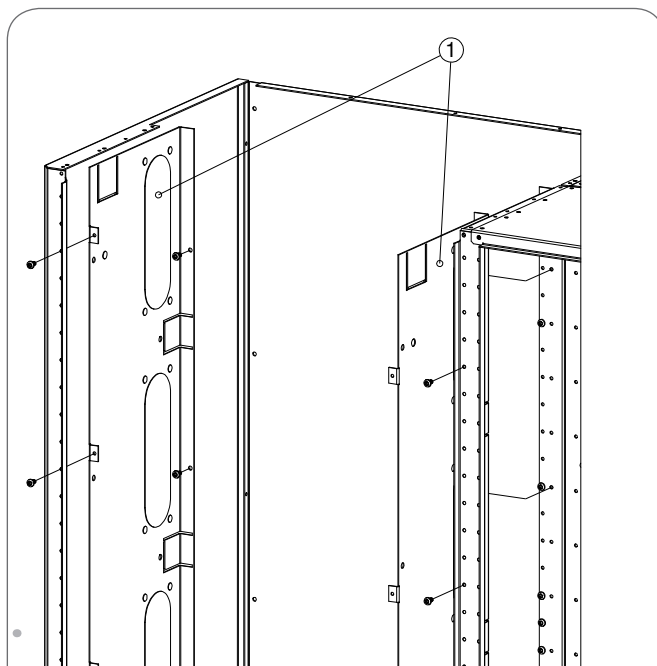

1. Divider (50028090)

Fig. 2.14 Dividers delimit cell centre fields from one another and cabling can be fed through them.

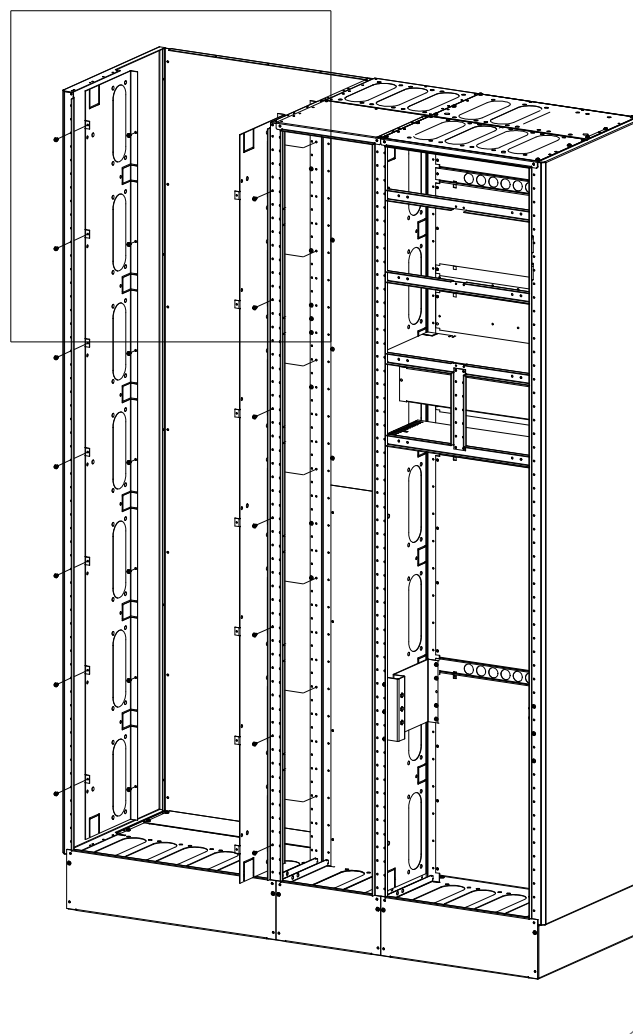

2.8 Drip covers and intermediate horizontal profiles

Drip covers (2) and intermediate horizontal profiles (1) are used for dividing fields into suitable spaces in the vertical direction for groups of electric components. The intermediate horizontal profiles (1) are fastened to front profiles and/or side plates. The drip covers are fastened with screws to the intermediate horizontal profiles and at the rear the mounting plates and feedthrough beads have rectangular holes to support the drip covers, see Fig. 2.15.



1. Horizontal intermediate profile 60 (50052111)
2. Drip cover plate, metal 60 (50027067)

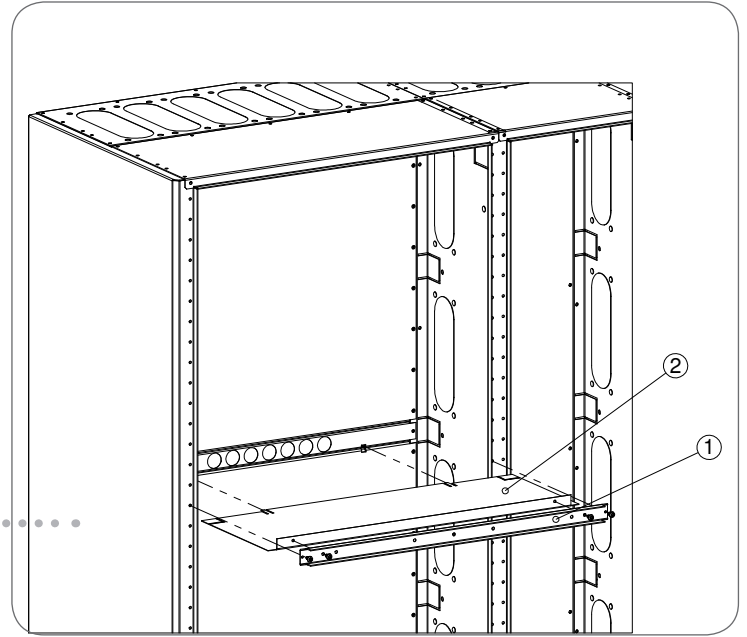

Fig. 2.15 Spaces for different component groups are delimited using drip covers (2) and intermediate horizontal profiles (1). At the rear, drip covers are supported by rectangular holes in mounting plates and feedthrough beads.

2.9 Mounting heavy components

Heavy components are mounted to the F-serie cell centre frame using heavy-duty hangers (1) and holders (2) as well as C rails (3) and C rail U nuts (4).

Heavy-duty hangers are fastened with screws to the frame and side plate / front profile. Heavy-duty holders are fastened to heavy-duty hangers using M6 hex. screws. C rails are fastened to heavy-duty holders using either M6 or M8 hex. screws and the U nuts of C rails installed inside the rail. Figure 2.16 shows the parts needed for mounting heavy components to the frame structure.



1. Heavy-duty hanger

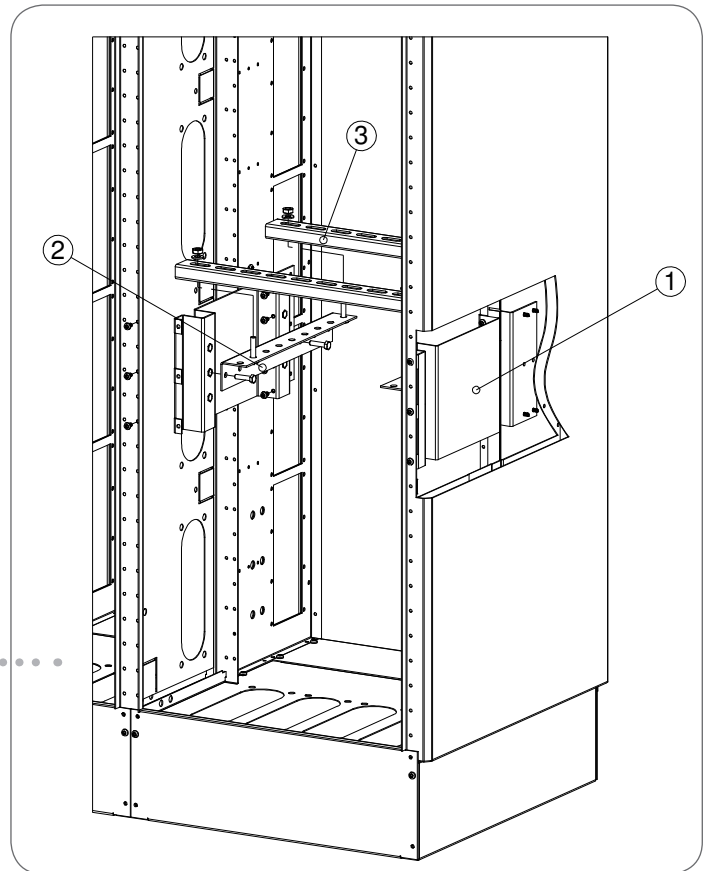
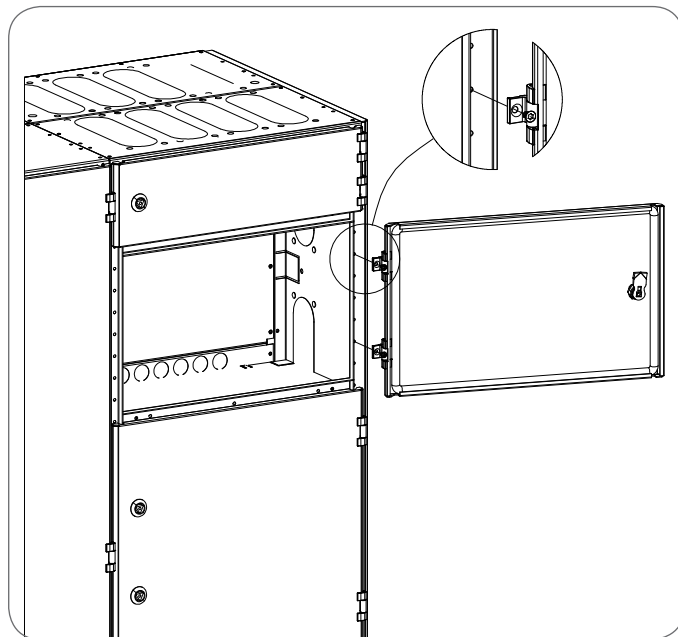

Fig. 2.16 Heavy components are mounted to the cell centre frame using heavy-duty hangers as holders, C rails and C rail U nuts.

2.10 Doors

Doors are fastened to side plates or front profiles using self-tapping M5*8 hinge screws with countersink head. If necessary, knock-out blanks are removed from the side plate or front profile at the hinge mounting location, see Fig. 2.17.

Fig. 2.17 Mounting doors to frame structure. Doors are fastened with screws to side plate or front profile.



2.11 Corner cell and other special parts

An F-serie cell centre can be made into L shape by using the corner cell structure that consists of cell centre special parts. There is a separate front plate (1), door (3), back plate (4) and roof (2) for corner cells. Figure 2.18 shows the special parts for corner cells.



- 1. Corner front plate of base
- 2. Corner roof
- 3. Corner door
- 4. Corner back plate
- 5. Back plate
- 6. End plate
- 7. Base back plate
- 8. End of base 25
- 9. Base plate
- 10. Intermediate base plate
- 11. Frame plate
- 12. Base end plate

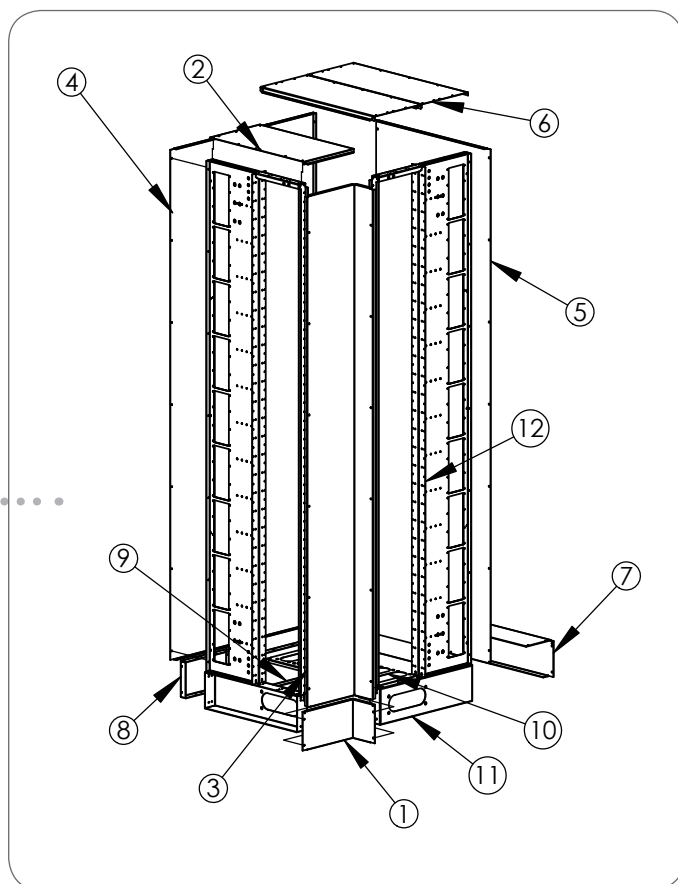

Fig. 2.18 Corner cell parts.

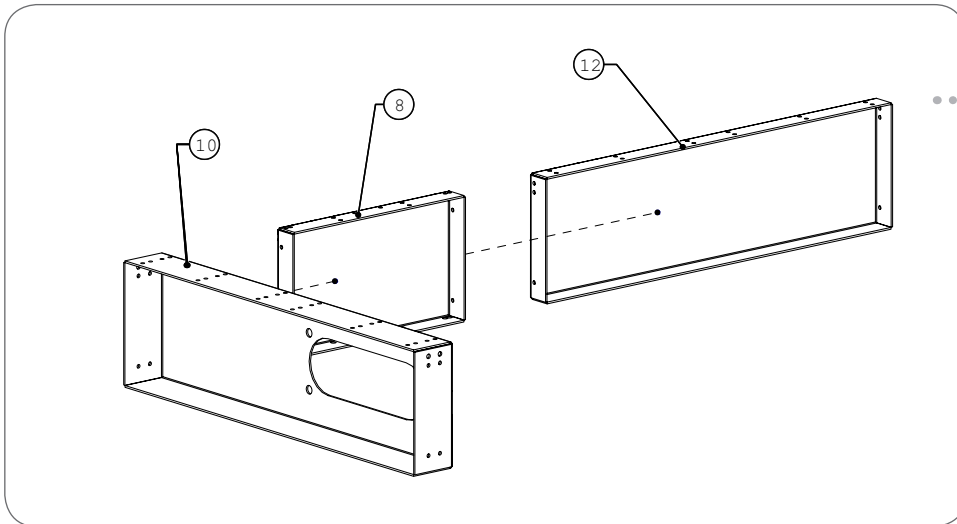

Fig. 2.19 Attach end of base 25 (8) to base intermediate plate (10) and to base end (12).

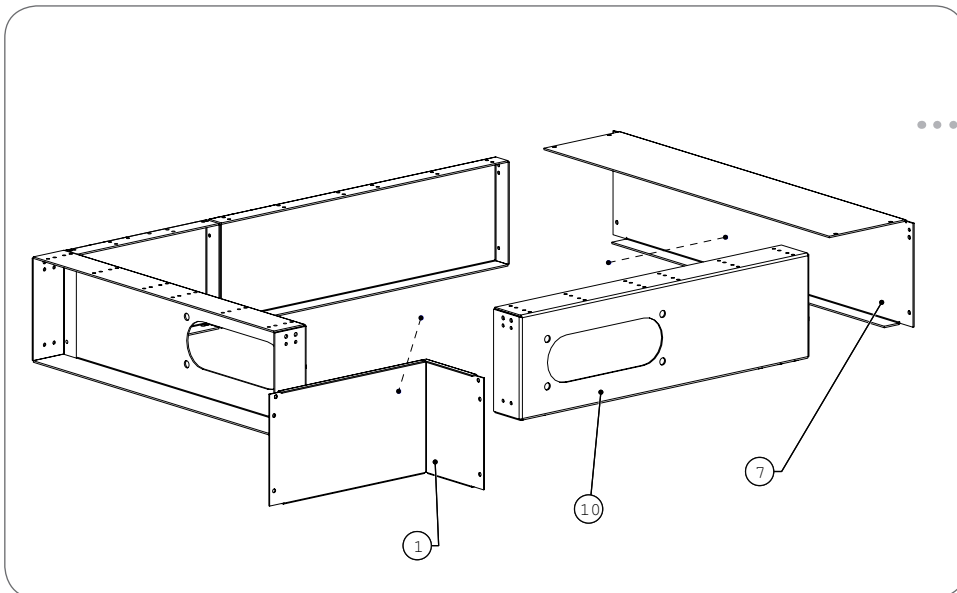

Fig 2.20 Attach base front corner plate (1) to base intermediate plates (10). Attach base back plate (7) to base end plate (12).

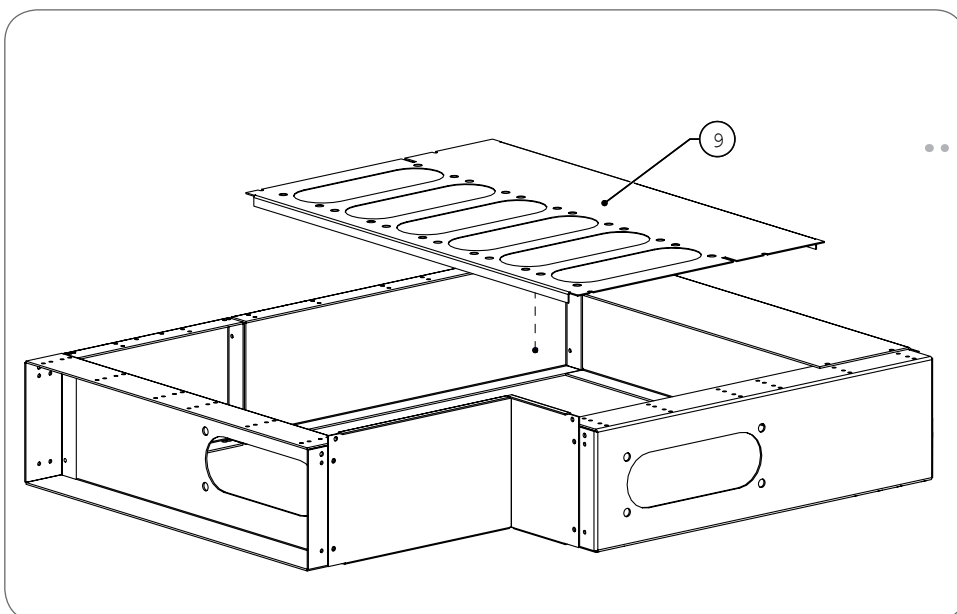

Fig 2.21 Attach base plate (9) to base intermediate plate (10) and base end plate (12).

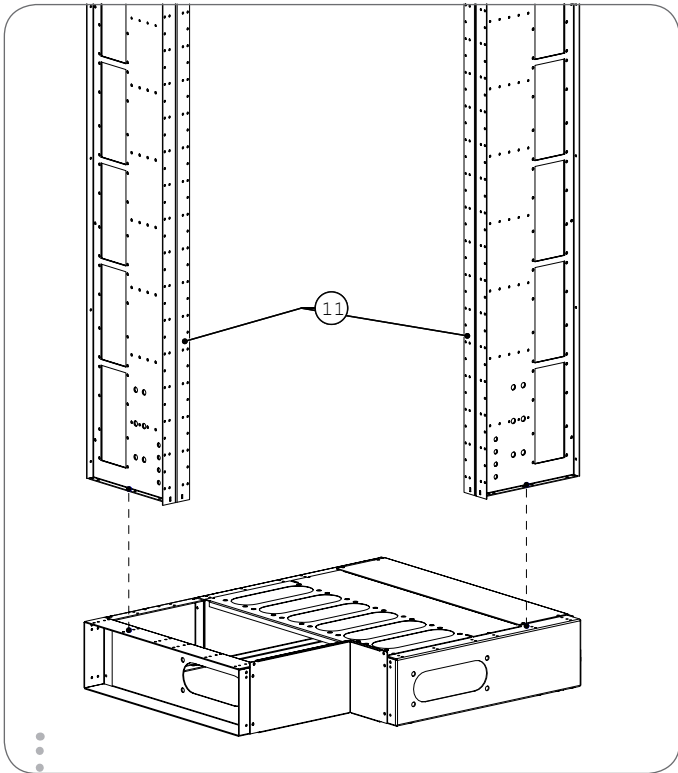

Fig 2.22 Attach frame plates to the base.

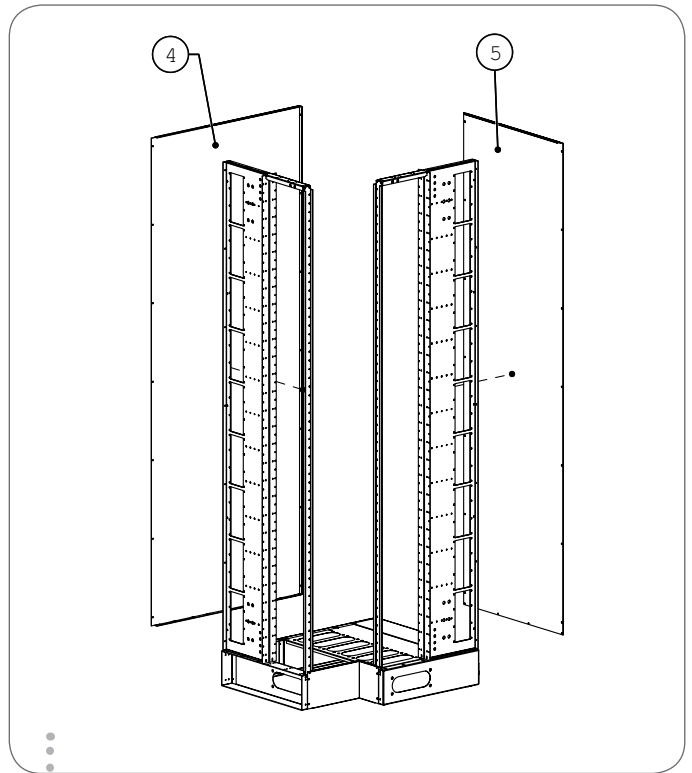

Fig 2.23 Attach corner back plate (4) to the frame plate. Then attach back plate to corner back plate and frame plate according to the picture.

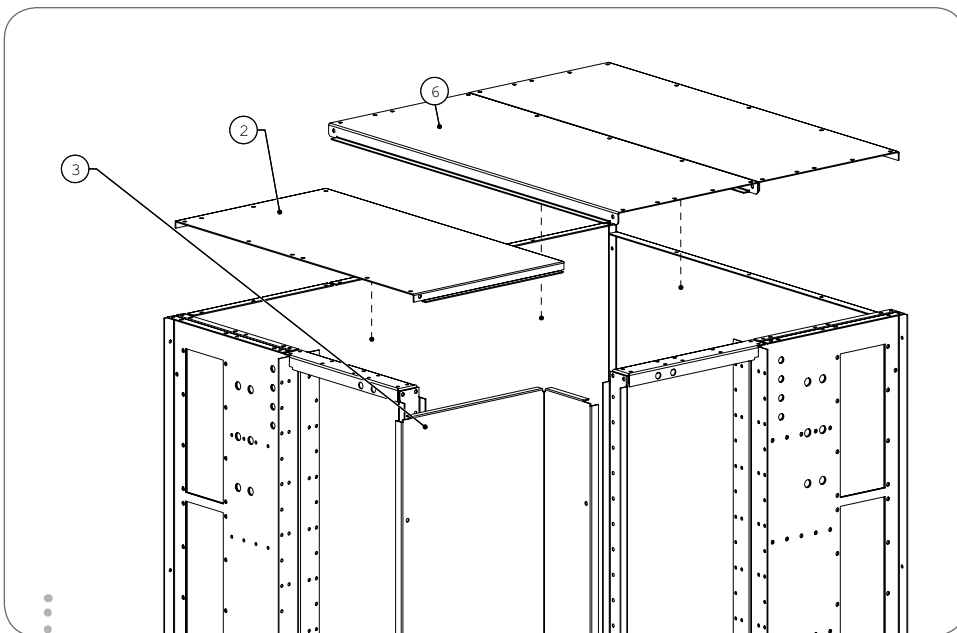

Fig 2.24 Attach end plates (6) according to the picture, then attach corner roof (2) and corner door (3).

3 SEALING

F-serie cell centres can be made to meet protection class IP55 requirements by using suitable strips and sealants at the joints. Without the use of sealing strips and sealants the protection class of the enclosure is IP20-IP30 depending on the cut-outs on the front profiles and intermediate horizontal profiles.

3.1 Degrees of protection

Degree of protection IP40

To reach class IP40 protection the joints at the top between fields and the ends shall be sealed and unperforated front profiles/side plates shall be used.

Degree of protection IP34

All plate joints shall be provided with 0.8*20 mm sealing strips and the ends of the intermediate profiles shall also be sealed. The middle joints of the cell centre roof and the front corners of the roof facing the door seal shall be sealed with sealant. The edges of possible C flange blanks on the roof shall be sealed with sealant.

Degree of protection IP44

In addition to the above sealing procedures, to reach class IP44 protection sealant shall also be applied to the vertical joints of the back plates.

Degree of protection IP55

To reach class IP55 protection, in addition to sealing strip either gluing putty or silicone sealant shall be applied to all joints in parts surrounding the frame structure (including the base). An at least 1.5 mm thick and wide strip of sealant shall be applied to the joint surface so that sealant is squeezed between the plates when the fastening screws are tightened.

The points where sealant shall also be applied are the door openings, i.e. the joints between the side plates and front profiles as well as end plates and intermediate horizontal profiles, see Fig. 3.1.

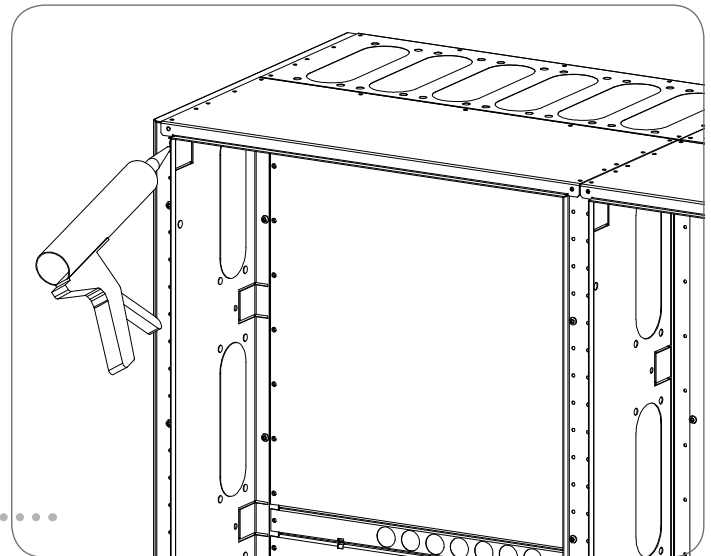

Fig. 3.1 Applying sealant to joints between end plates and intermediate horizontal profiles as well as side plates and front profiles.

3.2 Sealing of cell centre parts

The following chapters show how the different parts of the F-serie cell centre must be sealed to meet the requirements presented in Chapter 3.1.

Back plates

Attach sealing strips to the long sides and the lower side of the back plate as shown in Fig. 3.2.

End plates

Of the end plates, the short sides and the rear end facing the back plate shall be sealed according to Figure 3.3.

Side plates

Sealing strip is attached to the long side of side plates to face the frame plate, see Figure 3.4.

Intermediate profiles

When a high degree of tightness is required of the F-serie cell centre, the joint between the intermediate profile and the front profile shall be sealed with sealing strip according to Figure 3.5.

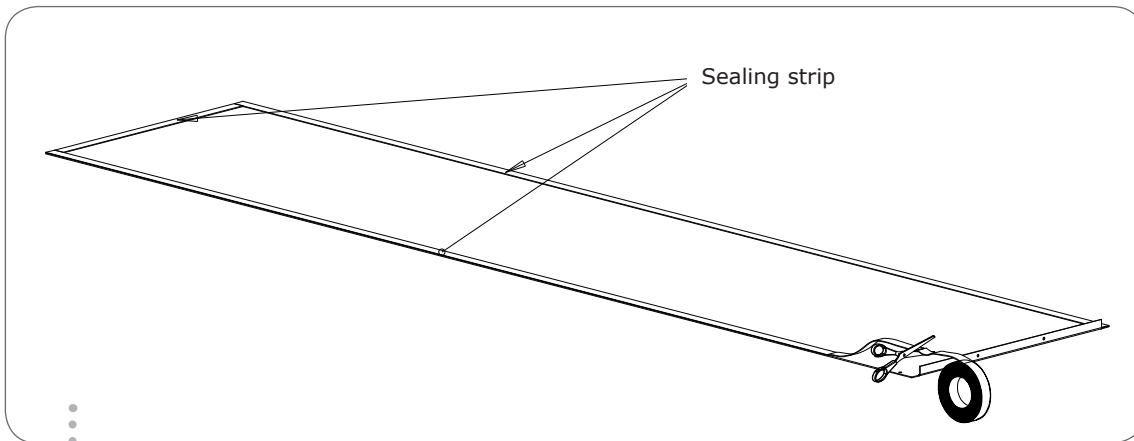

Fig. 3.2 Sealing long sides and lower side of back plate for F-serie cell centre with sealing strip (50020040 Joint sealing strip 0.8*20 mm).

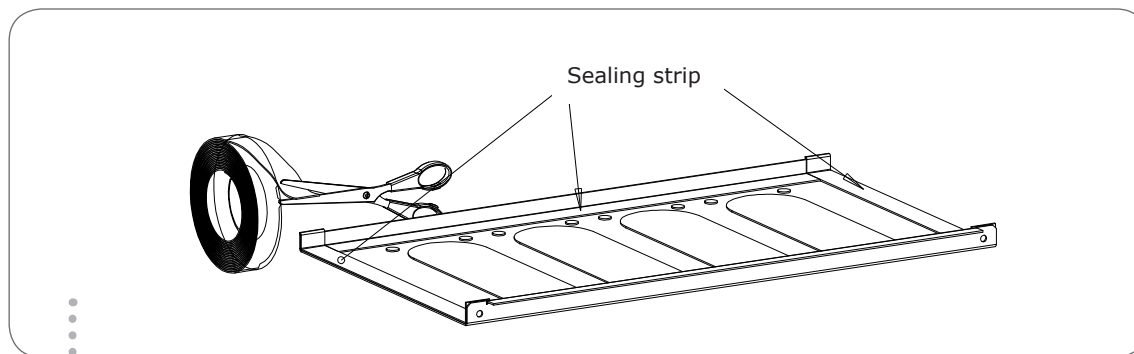

Fig. 3.3 Sealing of end plates. Sealing strip is attached to the short sides of end plates.

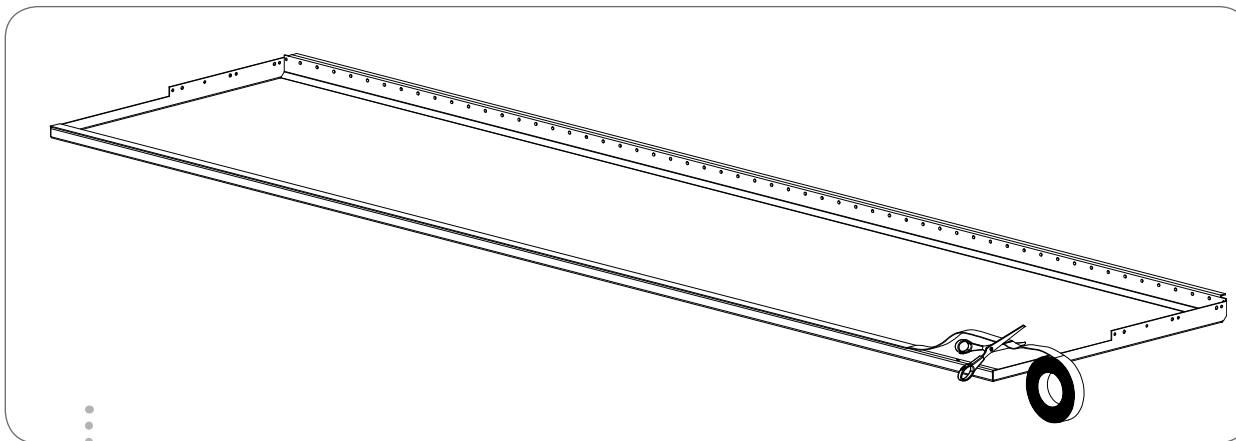
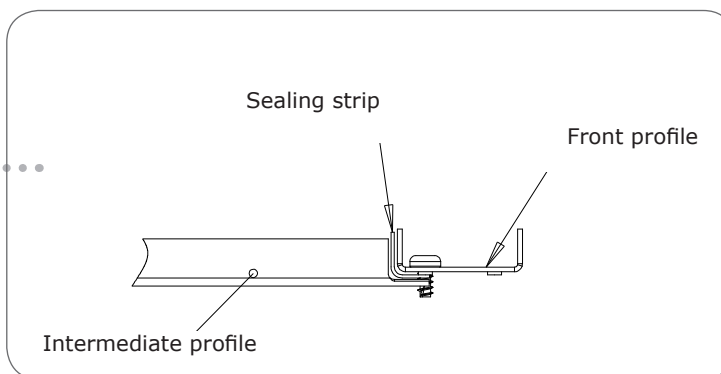

Fig. 3.4 Attaching sealing strip to side plate. Sealing strip is attached to the rear part of the side plate.

Fig. 3.5 Using sealing strip between intermediate profile and front profile



4 BUSBARS

Aluminium busbars were used in the temperature rise and short-circuit tests on the F-serie cell centres, see Table 4.1. The system does not, however, exclude the use of copper busbars that can be dimensioned applying the SFS5556 Standard, see Table 4.2.

F-serie busbar insulators (kute and kuten) shall be used as the insulator elements. With fields more than 450 mm in width intermediate insulators shall be used so that the distance between busbar insulators never exceeds 450 mm. The distance between insulators on vertical busbar systems may not exceed 450 mm, either, fig. 4.1.

Short-circuit resistance (I_{pk}) can be, as necessary, increased by using shorter insulator distance than 450 mm (=by adding the number of insulators). Added number of insulators has no effect on the thermal short-circuit resistance (I_{cw}).

No separate short-circuit tests were carried out for copper busbars. The short-circuit resistance values of aluminium busbars and busbar insulators of corresponding dimensions can be used for copper busbars.

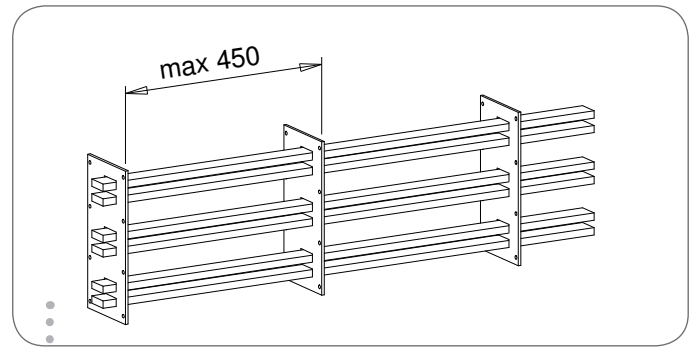

Fig 4.1 In F-serie system the insulator distance may not exceed 450 mm.

4.1 Constructing of busbar system and grouping of phases

The busbar system is constructed and the phases are grouped in the rear section of the cell centre according to Figure 4.1. The phase sequence is alternated as illustrated and the connections between vertical and horizontal busbars are made according to Chapter 4.5.

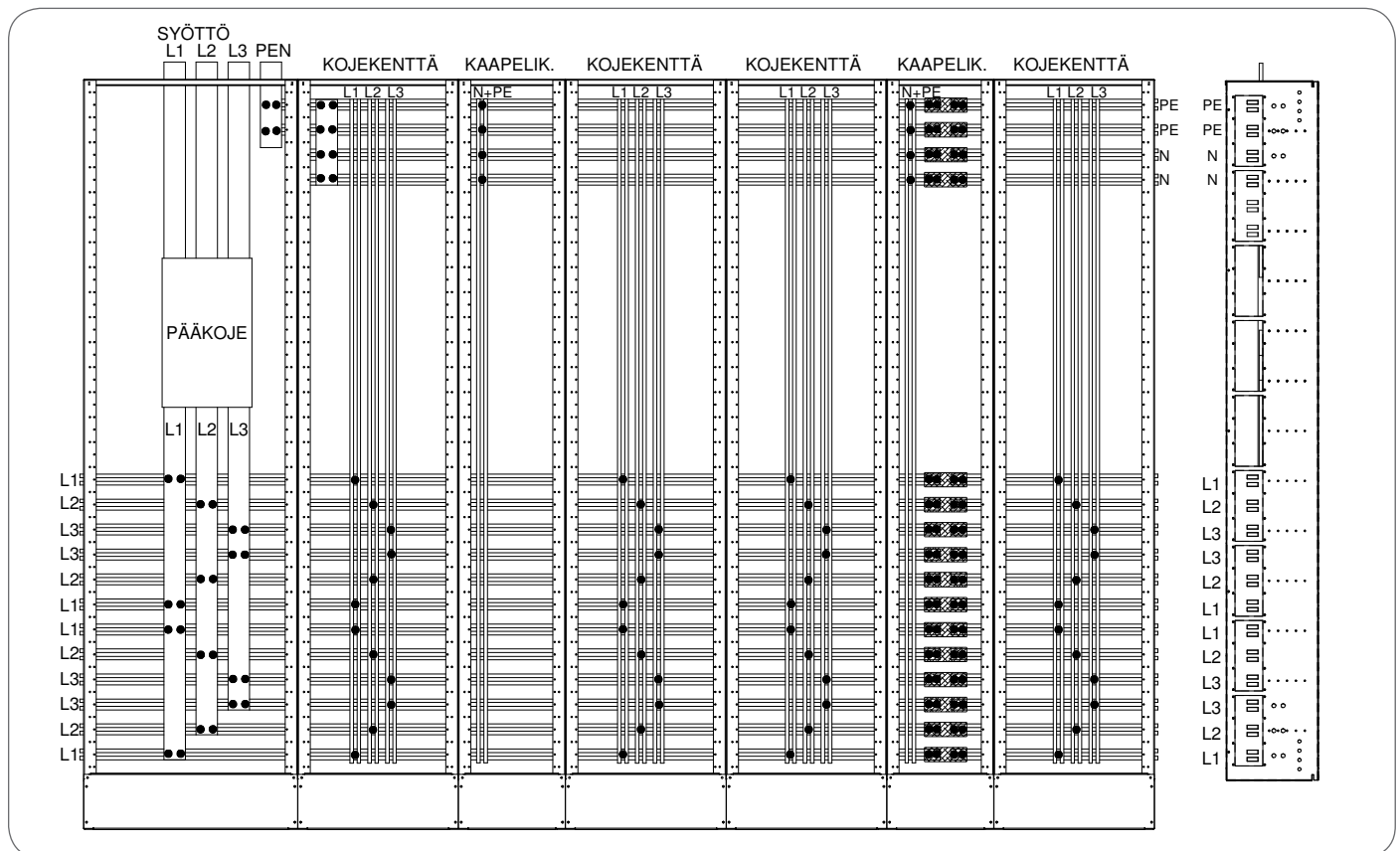

Fig. 4.2 An example of busbar system and installation arrangement in an F-serie cell centre. Black dots (•) indicate busbar connections.

4.2 Horizontal busbars

The horizontal busbar system is installed into the busbar space of the cell centre using frame plates and busbar insulators. The F-serie system uses polycarbonate busbar insulators available for 10x10 – 10x50 busbars.

For enclosures with higher protection class than the one given in Tables 4.1 and 4.2 (e.g. from IP30 to IP44) the ratings for busbars would be about 20-25% lower than the values given in the Tables.

4.3 Vertical busbars

Table 4.3 shows the rated currents and the results of the short-circuit and temperature rise tests for vertical busbars in F-serie cell centres.

According to IEC/EN 61439-1 (Chapter 7.5.5.1.2) the busbars (e.g. branch busbars) and conductors between power busbars and the operating unit feed connections as well as the devices within operating units can be dimensioned field-specifically on the basis of the loads caused by a short-circuit behind the short-circuit protector. In other words, the short-circuit resistance of vertical/branch busbars need not be equal to the horizontal power busbars.

4.4 Equipment earthing

The purpose of equipment earthing is to protect the user against the effects of possible faults in the cell centre or in the external circuit feeding the cell centre. The equipment earthing circuit of the cell centre consists of separate protective conductors or conductive structures or both.

4.4.1 Protective earthing of frame

The frame plates and dividers of the F-serie cell centre system are provided with holes that can be used for connecting protective earthing for the frame. Using M8 screws you can connect max. one 70mm² protective conductor of copper. At this point you must make sure that the connector used provides a sufficient contact area to the frame.

Rated current I_n [A]	Number of busbars/phase	Al busbar size	Short-circuit resistance I_{cw}/I_{pk} [A]*10 ³
400	2	10*20 (1)	17,2/34,1
630	2	10*30 (1)	21,6/42,6
800	2	10*40 (1)	21,6/42,6
1000	2	10*50	24,0/50,4
1250	4	10*30	21,6/42,6
1600	4	10*40	31,5/66,2
2500	6	10*40	40,0/84,0
3150	8	10*40 (1)	60,0/132,0

Table 4.1 Ratings for aluminium (E-AlMgSi-T6) busbars in the F-serie cell centre (conductivity 31,9m/Ωmm²), protection class IP30. Temperature rise tests have been carried out for the marked (1) busbars.

Rated current I_n [A]	Number of busbars/phase	Cu busbar size
400	2	10*10
630	2	10*20
800	2	10*20
1000	2	10*30
1250	2	10*40
1600	2	10*50
2500	4	10*40
3150	4	10*50

Table 4.2 Calculated ratings for copper (E-Cu F30) busbars in the F-serie cell centre (conductivity 56m/Ωmm²), protection class IP30. Table according to SFS5556 for busbars lying flat, maximum permissible temperature-rise of the busbar is + 30 celcius (end temperature + 65 celcius).

Rated current I_n [A]	Number of busbars/phase	Al busbar size	Short-circuit resistance I_{cw}/I_{pk} [A]*10 ³
250	2	10*10	7,5/12,8
400	2	10*20	7,5/12,8
630	2	10*20	7,5/12,8
800	2	10*30	23/48,3
1000	2	10*40	24/50,4

Table 4.3 Ratings for vertical Al busbars. Temperature rise tests have been carried out for the marked (1) busbars.

According to IEC/EN 61439-1 the cross section of a protective conductor can be calculated from

$$S_p = \frac{\sqrt{I^2 t}}{k} \quad (4.1)$$

The equation is used for calculating the cross section for a protective conductor capable of sustaining the thermal load caused by a current of short duration. Table 4.5 contains some protective conductor cross sections calculated using equation 4.1.

Installing PE busbar

The PE busbar is installed in the F-serie cell centre system to the front part of the equipment space using PE busbar holders. The PE busbar is connected using connectors that are suitable for PEN, PE, N, main potential equalizing and frame protective earthing connections according to SFS 154 (e.g. YKPEN and YKOL connectors).

4.4.2 Protective earthing of covers and doors

Protective earthing of covers and doors to the frame structure is provided through the direct contact of their unpainted rear parts and the contact surfaces of their fastening screws. Components with max. 16 A rated current can be mounted to doors without separate protective earthing conductor. For higher currents, doors must be provided with separate protective earthing using a conductor that is connected to the door through either a screw and nut connection or a protective earthing screw welded to the door.

4.5 Connecting of busbars

The power busbar system is installed in the rear part of the F-serie cell centre using frame plates and busbar insulators. The F-serie cell centre has been tested using horizontal and vertical busbars of aluminium with their rated values given in Chapters 4.2 and 4.3.

To connect conductors to the busbars and busbars to each other you can use various types of busbar connectors.

Cross-section of phase conductor S [mm ²]	Min. cross-section of corresponding protective conductor (PE, PEN) S_p [mm ²]
$S \leq 16$	S
$16 < S \leq 35$	16
$35 < S \leq 400$	$S/2$
$400 < S \leq 800$	200
$800 < S$	$S/4$

Table 4.4 Cross-sectional area (IEC/EN 61439-1) of protective earth conductor (PE, PEN).

Rated thermal current resistance of cell centre I_{cw} [A]·10 ³	PVC insulated copper conductor Cu [mm ²]	Aluminium busbar 10x30 mm
5	35	1
6	50	1
10	70	1
12,5	2x50	1
16	2x70	1
20	2x70	1
25	3x70	2
32	4x70	2
40	4x70	2
50	5x70	3
63	7x70	3

Table 4.5 Protective earthing of frame according to rated thermal current resistance (I_{cw}).

SFS 154 provides comprehensive information on connectors for aluminium conductors and connections of aluminium busbars. The Table below gives tightening torques for aluminium connections..

Connecting feed and power busbars

The busbars feeding the cell centre can be connected to the horizontal power busbars as shown in Figure 4.2. Pieces of suitable Al busbar are placed between the feed busbars. Busbars are connected together using screws and nuts as well as various types of connecting pieces and washers.

Connecting vertical and horizontal busbars together

Vertical and horizontal busbars are connected together, as necessary, using YKG busbar connectors, see Fig. 4.3.

Screw size	M6	M8	M10	M12	M16
Tightening torque [Nm]	6...9	15...22	30...44	50...75	120...190

Table 4.6 Tightening torques for Al connection screws.

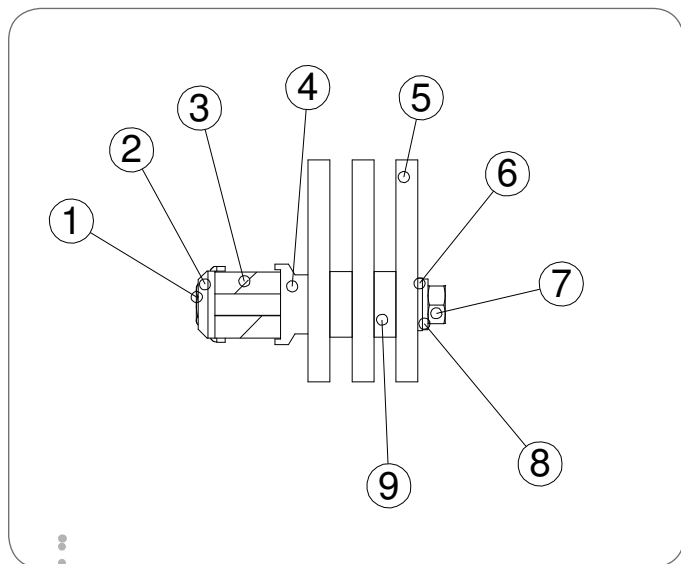

1. Zined M10 nut (class 8)
2. SFS3737 conical spring washer
3. Vertical busbars
4. Connecting piece YKG 51/30
5. Horizontal busbars
6. Special washer YKG 28.3 M10
7. Zined washer YKG 44
8. Zined hex head screw M10 (class 8.8)

Fig. 4.3 Connecting vertical and horizontal busbars using YKG busbar connectors.

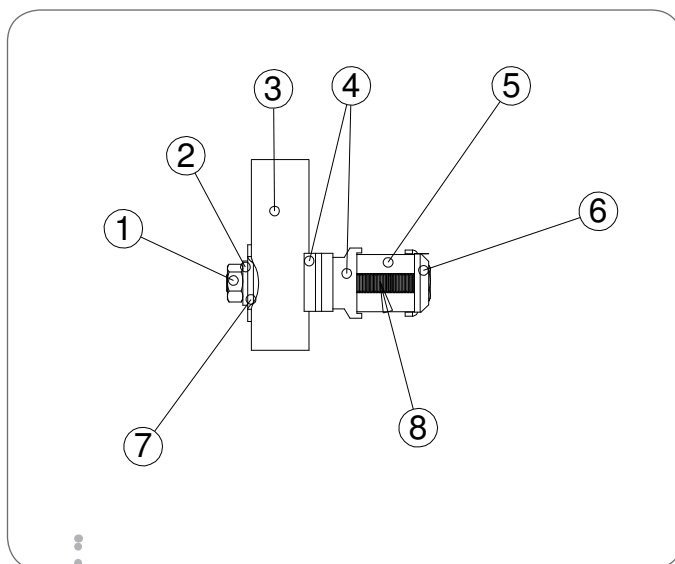

1. Zined M10 hex head screw (class 8.8)
2. Special washer YKG 28.3 M10
3. Horizontal power busbars
4. Connecting piece YKG 51/30
5. Feed busbars
6. SFS 3738 pressure washer
7. Zined M10 nut (class 8)
8. SFS3737 conical spring washer
9. Spacer piece, e.g. of 10*30 Al busbar

Fig. 4.2 Connecting feed and horizontal power busbars together.

When making the connections you shall ensure that the requirements on aluminium connectors and connections presented in the SFS handbook 154 (in Finnish), Chapter 7.1.3, are met. For example, the mating surfaces of the connection must be deoxidized and the cleaned surfaces protected with connection grease.

Transport break

Any break points made into the cell centre and power busbar system should be located at a cable field to make reconnecting of busbars easier. Busbar joints are made using, for example, YKG 51/120 aluminium profiles and M10 screws and nuts, see Fig. 4.4.

When reconnecting, the busbar parts are matched together. The connecting pieces are placed symmetrically over the joint, and the screws are tightened to the correct

4.6 Arc protection

Arc protection in the F-serie cell centres involves the replacement of the normal rear end plate at the top by a roof plate provided with a hinged hatch. The roof hatch shall be sealed with sealing strip, as necessary. The door latch is replaced by a special plastic latch that allows the roof hatch to open under arc pressure.

The spreading of arc is restricted by installing cover plates on the unused mounting holes for busbar insulators on the frame plates. In addition, feedthrough beads shall be installed between mounting plates.

The F-serie cell centre has been tested for arc short-circuit according to IEC 61641 and it complies with the criteria presented in the Standard when the short-circuit current is 41.9kA and the duration of short-circuit is 0.3s.

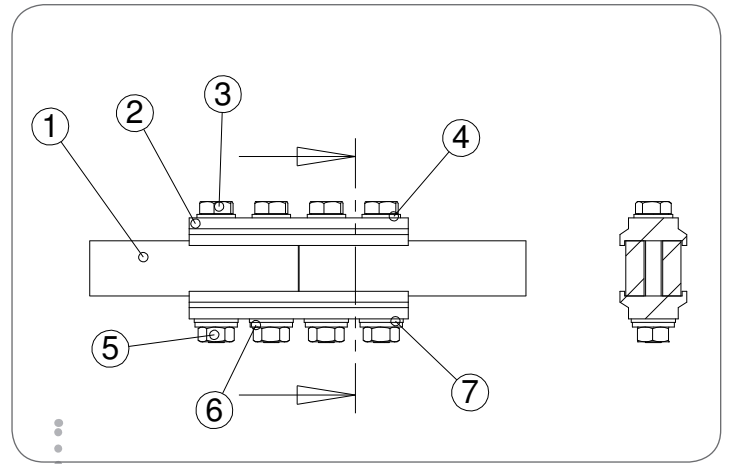

- 1. Power busbar
- 2. YKG 51/120
- 3. Zincd M10 hex head screw (class 8.8)
- 4. SFS3738 pressure washer
- 5. Zincd hex nut (class 8)
- 6. SFS3737 conical spring washer
- 7. SFS3738 pressure washer

Fig. 4.4 Connecting of busbars at a transport break. The busbars are connected using connecting pieces of aluminium (e.g. YKG 51/120), M10 screws and nuts, and various washers.

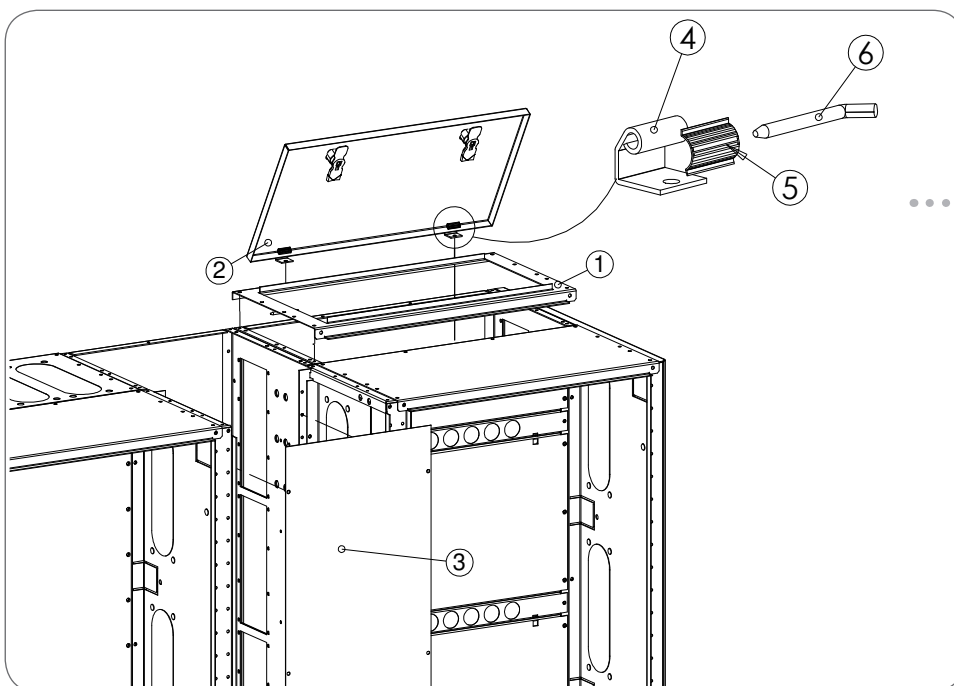

Fig 4.5. Arc protection by using pressure discharging roof.

- 1. Roof plate
- 2. Roof access door
- 3. Busbar protective cover
- 4. Hinge
- 5. Hinge flop
- 6. Hinge pin

5 LIFTING AND TRANSPORTING

5.1 Transport break

The F-serie cell centre can be, as necessary, separated into two or more sections for transport. At the break point, the base dividers are replaced by two base end plates (1), the end supports by extension end supports (2), and the front profiles by extension front profiles (4), see Fig. 5.1. The transport break point should be located at either side of a cable field in order to make busbar reconnecting easier.

The cell centre transport sections are connected together using M10 screws and nuts at the top and bottom of the frame plates and smaller assembly screws in the middle, as necessary.

It is not necessary to have two front dividers at the transport break, as shown in Figure 5.1 where the other front divider is replaced by a few 250 mm intermediate supports (3).

- 1. Base end plate (50028070)
- 2. Extension end support, pair 25 (50028060)
- 3. Intermediate support 25 (50026072)
- 4. Extension front profile 196 (50028020)

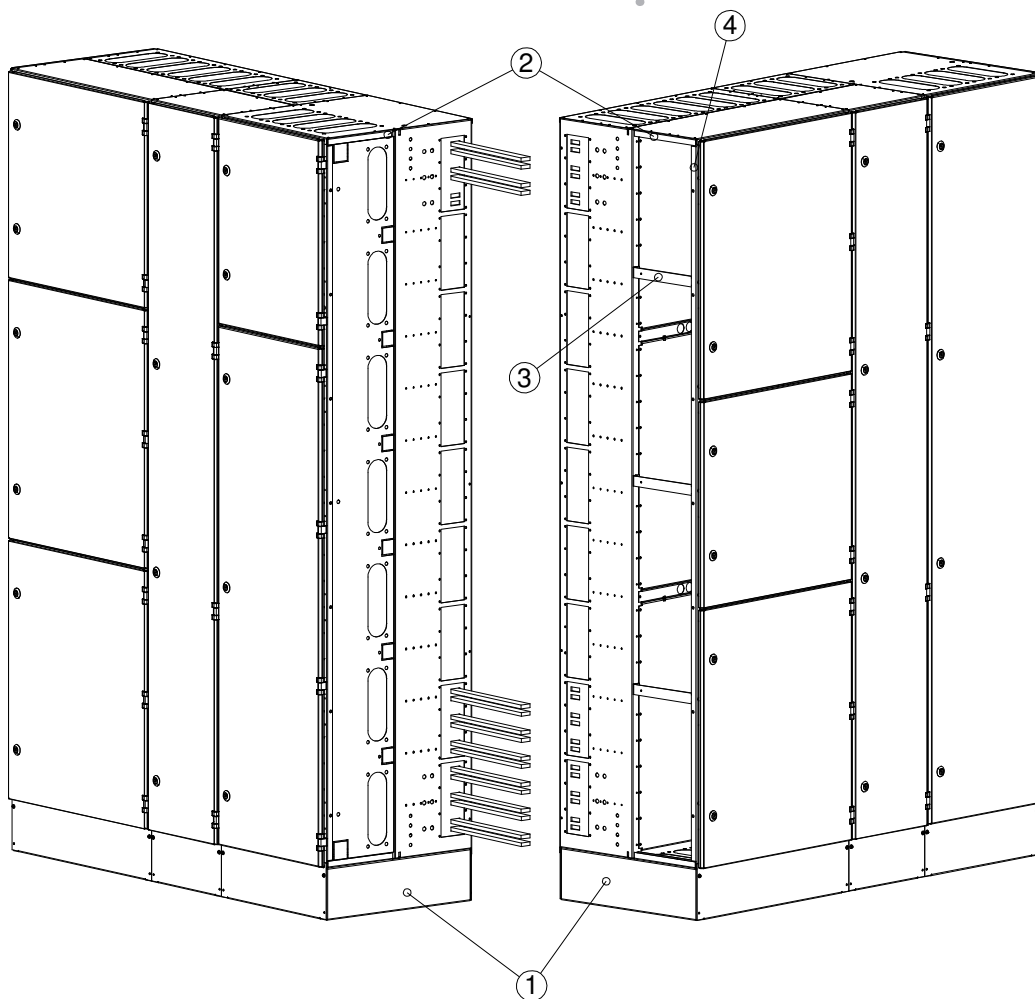

Fig. 5.1 Structure of transport break.

5.2 Lifting

For lifting, brackets and eyes described in Chapter 2.2 are installed to the frame plates of the F-serie cell centre. The M12 lifting eye used on the F-serie cell centres complies with the DIN580 Standard. The lifting capacity of one eye is 340 kg. If the lifting angle is 45°, two lifting eyes provide 480 kg total lifting capacity.

Short cell centres can be lifted by attaching the hooks directly to the lifting eyes, but with longer cell centres we recommend the use of a lifting beam in order to avoid excessive sideways loads on the lifting eyes.

Figure 5.2 shows the lifting of cell centres using either wire ropes or a lifting beam.

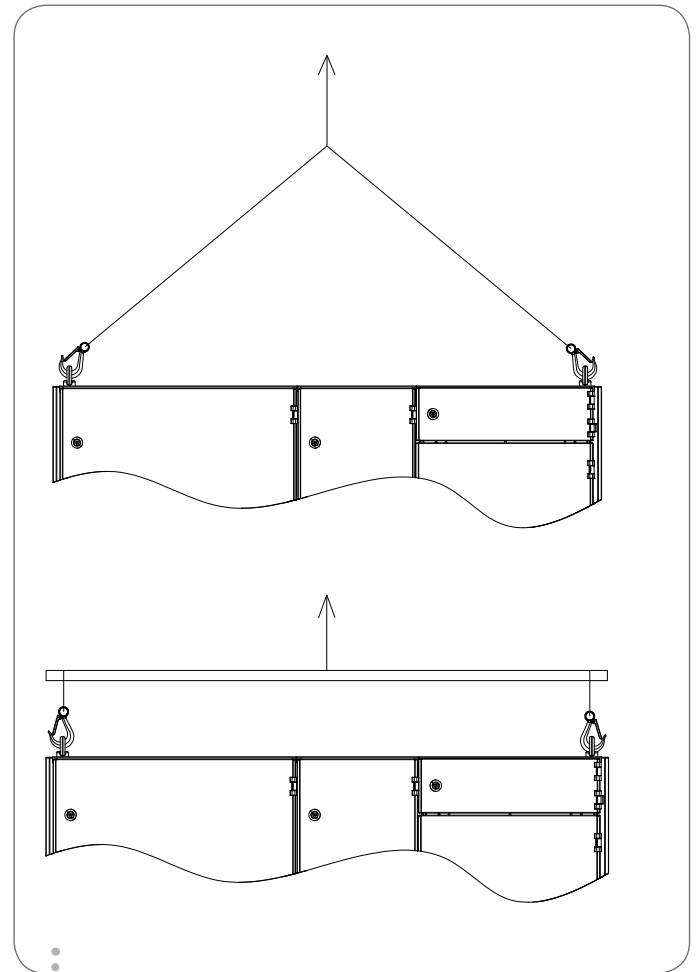

Fig. 5.2 Lifting F-serie cell centres using wire ropes or lifting beam. Using a lifting beam gives higher lifting capacity than wire ropes.

6 OTHER INFORMATION

The F-serie cell centre system is intended for use as a protective enclosure for distribution, control and automation centres as well as electronic devices.

Compliance

When assembling centres using the F-serie system you should ensure with, for instance, piece tests (standard series IEC/EN 61439, Chapters 8.1.2 and 8.3) that the structural solutions of the delivered centres comply with the type tested centre and meet the requirements of the standards that for the basis for certification.

In addition to the examples in these instructions the requirements and regulations in the IEC/EN 61439 Standard shall be observed when assembling the power busbar system as well as the whole distribution centre. When using the structure you should also consider the various product standards according to which the final enclosed product shall be made.

When assembling the structure you shall utilize the specified screws, lifting eyes, washers, hinges, the components used in tests or corresponding components, and follow the assembly and operating instructions provided by the centre mechanics supplier.

The dimensioning of the instrument mountings on the mounting plates complies with the SFS 2529 Standard. Instrument spaces comply with the SFS 5601 Standard.

Manufacturer reserves the right to technical changes.

Compatibility

The parts of the electric centre enclosure systems manufactured by Suomen CNC-Metal Oy are primarily compatible with one another, for instance, the doors and mounting plates are compatible with all systems.

Independency of components

The frame structure and fastening mechanics are designed so that the commonest and standardized electric and mechanical components (e.g. components mounted to DIN rails, feedthrough flanges) are easy to install to the structure. The structures of the F-serie cell

centre are not component-dependent, in other words, you can use the components of any components manufacturer.

Safety distances

In the design of the F-serie cell centre attention has been paid on the safety distances between live parts and the conductive parts of the frame. Both surface and air gap distances in the F-serie cell centre are at least 7 mm.

Static loads

Depending on the size, the mounting plates of the F-serie cell centre are made of either 1.5 or 2.0 mm hot-galvanized steel sheet. The structure and the mounting plates can be statically loaded by 2 kg/dm² of mounting plate with components fastened to the mounting plate. In this case, the number of mounting plate screws shall be at least equal to the mass of the component divided by two (2), however, not less than four (4) mounting screws.

Components can be mounted to doors and covers as necessary. The maximum load from components mounted to doors is 0.5kg/dm², but in addition to the door weight not more than 6 kg per door hinge. For covers fastened with screws, the loads may not exceed 0.25kg/dm² but shall, however, be less than 1 kg/fastening screw of cover.

7 TECHNICAL DATA

General

The F-serie cell centre is an according to 60439-1 Standard tested cell centre with fixed output units.

Insulating voltage U_i	$\leq 1000V$ (AC)
Rated voltage U_n	$\leq 690V$ (AC)
Rated current I_n horizontal power busbars	$\leq 3150A$
vertical busbars	$\leq 1000A$
Thermal short-circuit resistance I_{cw}	17,2-60kA/1s
Dynamic short-circuit resistance I_{pk}	25,6-132kA
Rated frequency	50-60Hz
Protection classes	IP20-IP55
Impact strength	IK09
Nominal dimensions	
depth	510mm
field widths	200, 300, 450, 600, 750mm
height	1720-2100mm
Material	
frame and enclosure	hot-galvanized steel sheet 275MAC
busbar insulators	polycarbonate, PC
Surface treatment	
end plates, doors, side plates	powder paint, must be ordered separately

Cross-sections and dimensions of F-serie cell centre

Appendix I

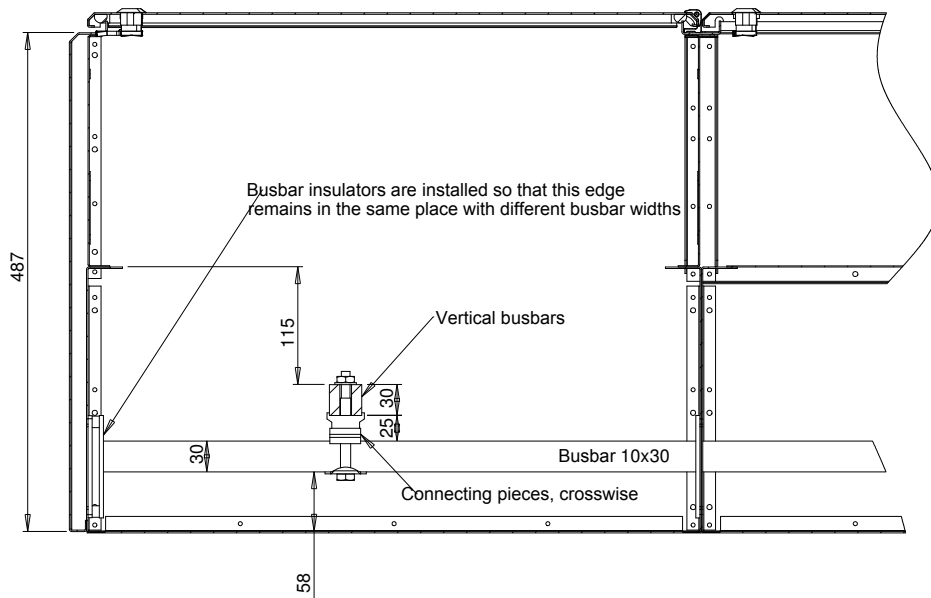
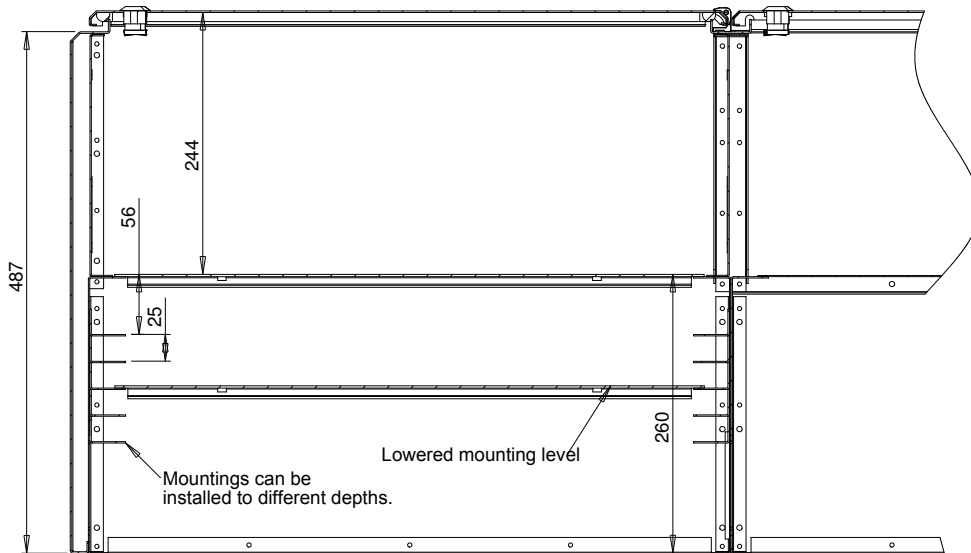

8 ENCLOSURE ASSEMBLY INSTRUCTIONS

The F-serie enclosure system is assembled starting from the enclosure base if applicable. The assembly of an enclosure without a base is started by joining the back plates and back profiles using screws or rivets. Preassembled basic frame packages can be fastened together using either screws or rivets.

When the basic frame is assembled, you can start installing the electric components into the cabinets by first installing the mounting plates. Another alternative is to add side plates, end plates, and end supports to the structure. Front profiles, intermediate supports, and dividers are used for delimiting the different fields in the horizontal direction, whereas intermediate covers and drip covers are used in the vertical direction.

8.1 Base

The assembly of base for the F-serie system is started by joining with screws the back (3), front (4), and side (1) and intermediate plates (2) needed for the base arrangement, base plates joining is shown (5) in Fig 8.1.

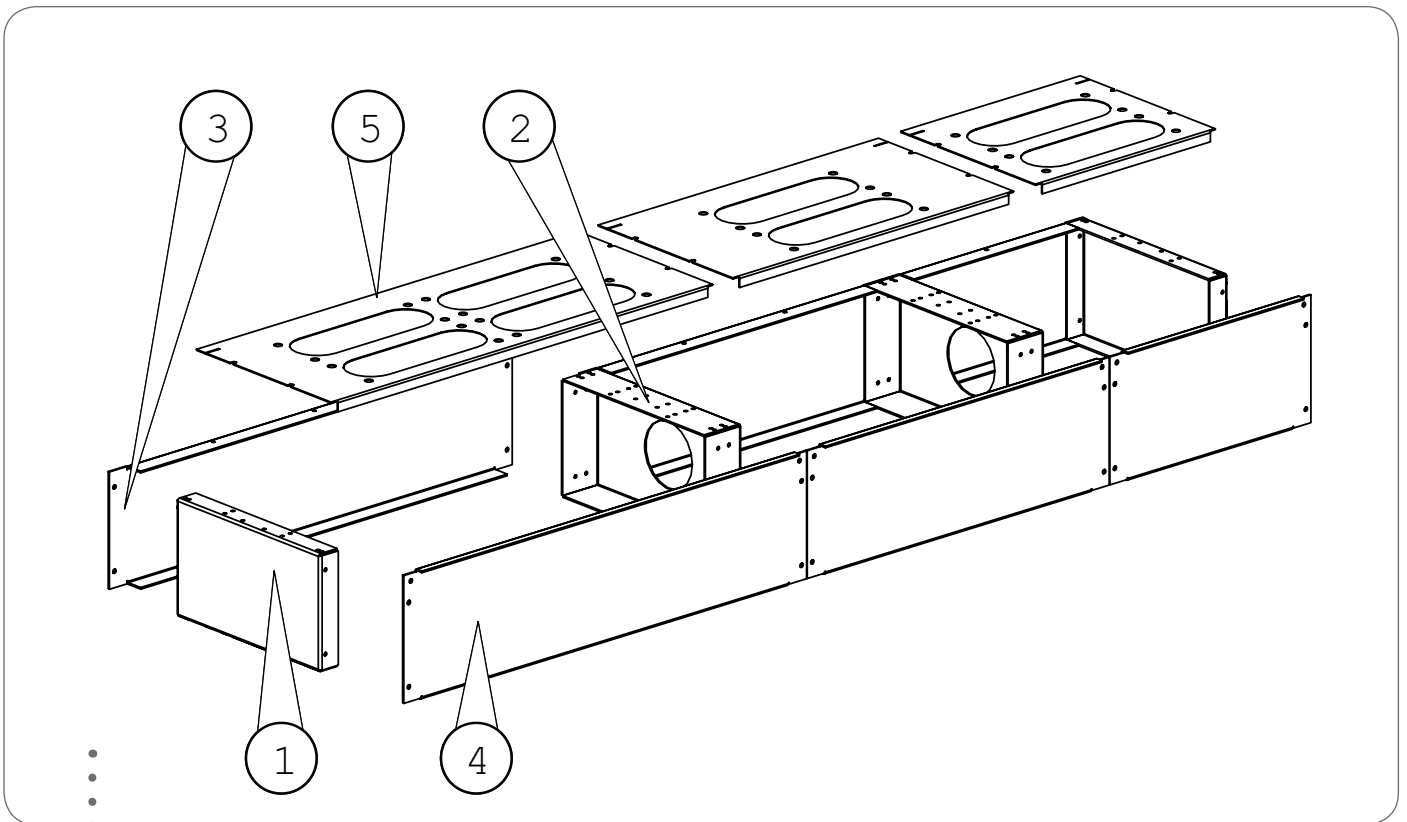

Figure 8.1. F-serie system base assembly.

8.2 Enclosure assembly

Basic enclosure assembly is shown in following figures. Multifield enclosure assembly are started by joining back profile (2) to back plates (1) in Fig. 8.2.1.

The single field enclosure installation starts with the attachment of the side plates (3) to the base plates, see 8.2.2.

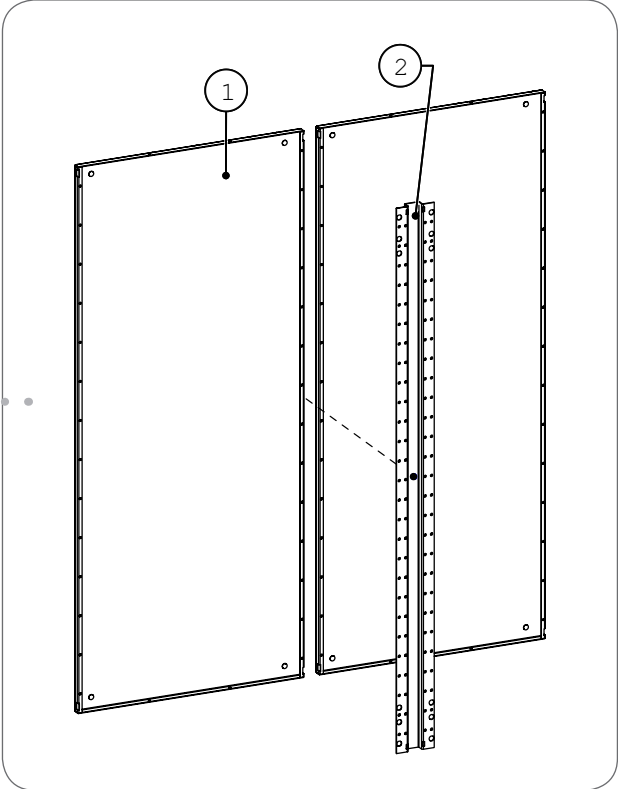

Fig 8.2.1 *Joining back profile to back plates.*

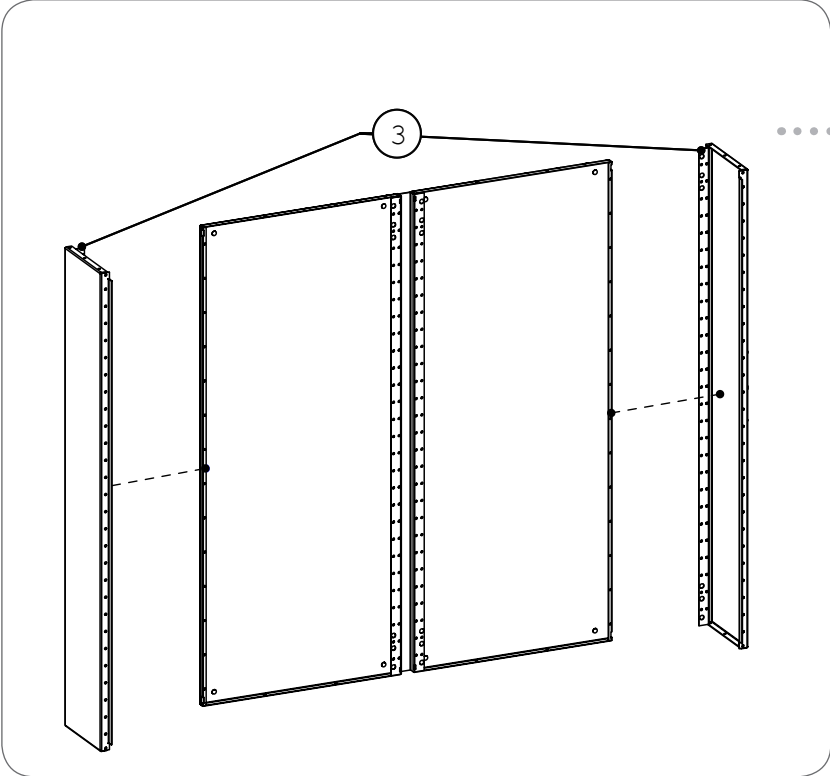

Fig 8.2.2 *Joining side plates.*

After the side plates are joined. End supports (4) are joined to the enclosure, shown in figure 8.2.3. By the installation of the single field enclosure, install directly the end plates (5) without the end supports, see 8.2.4.

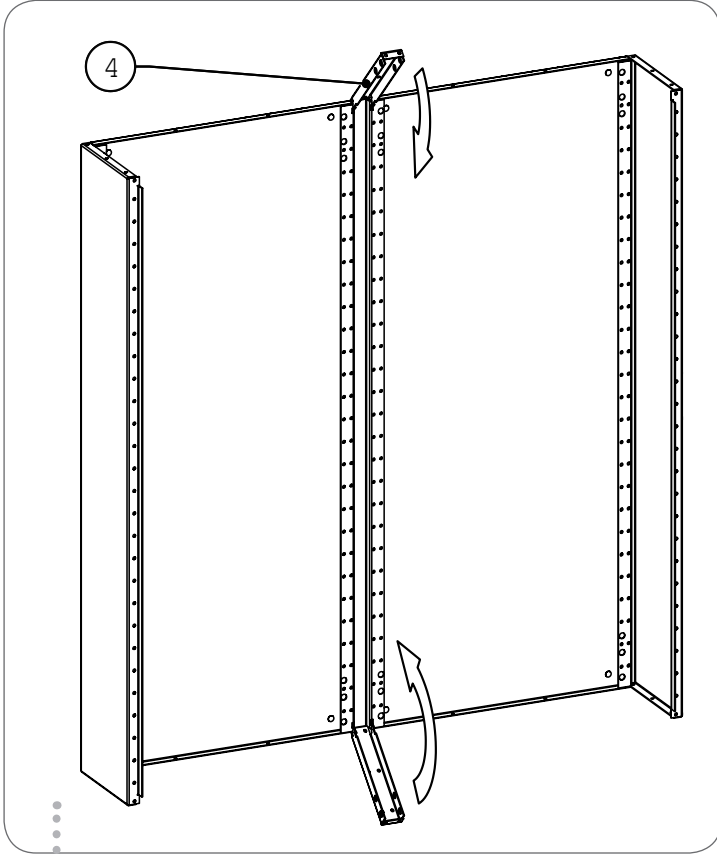

Fig 8.2.3 Installing end support.

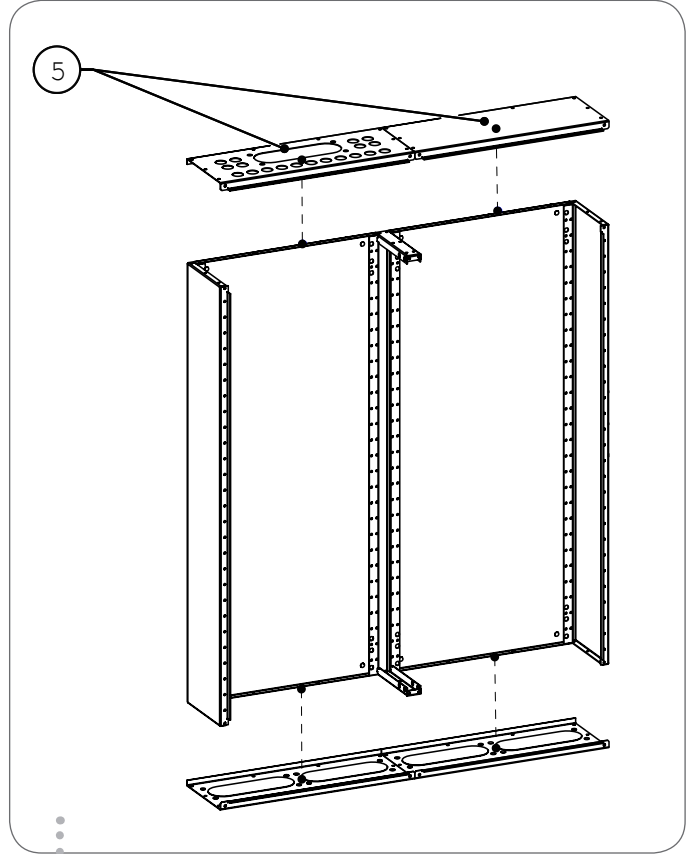
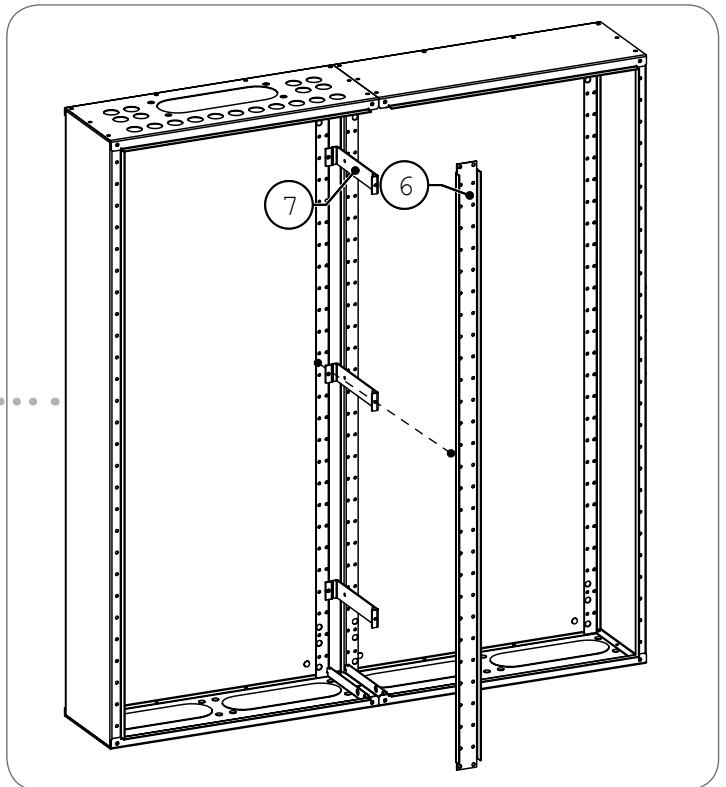

Fig 8.2.4 Installing end plates.

If the enclosure center is built up on top of the base line (fig. 8.1.), the lower end is fixed with the base bottom plates instead of the lower end plates (5, fig. 8.1.). By the multi field enclosures the spaces are divided with the installed intermediate supports (7) between the back and front profile (6).



Fig 8.2.5 Installing intermediate support (7) and front profile (5).



Drip covers divide the assembled centre in the vertical direction into cells for electric components. In addition to drip protection, the drip covers also act as touch screens and correctly installed they provide the internal parts with Class IP20 touch screening.

Figure 8.3.1 a) shows how the drip cover rear part is installed to the L profiles. The front part of the drip cover (2) and the horizontal intermediate profile (3) are fastened with screws as shown in Fig. 8.3.2. b).

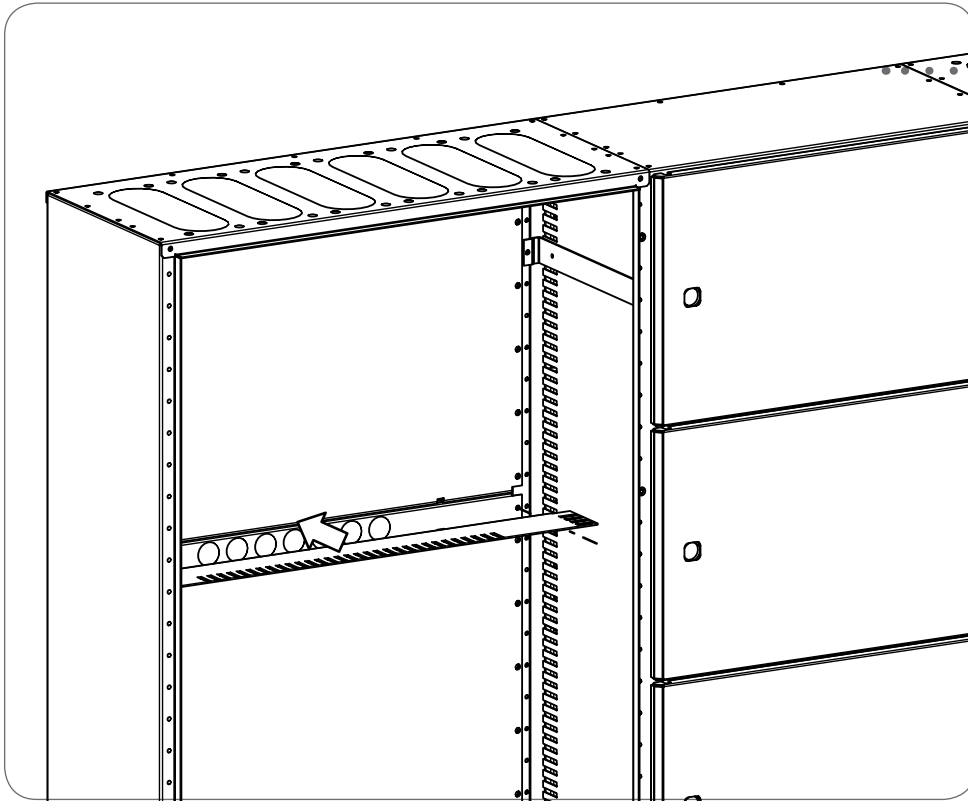

Fig 8.3.1 Drip cover rear part is fixed with screws to L profiles.

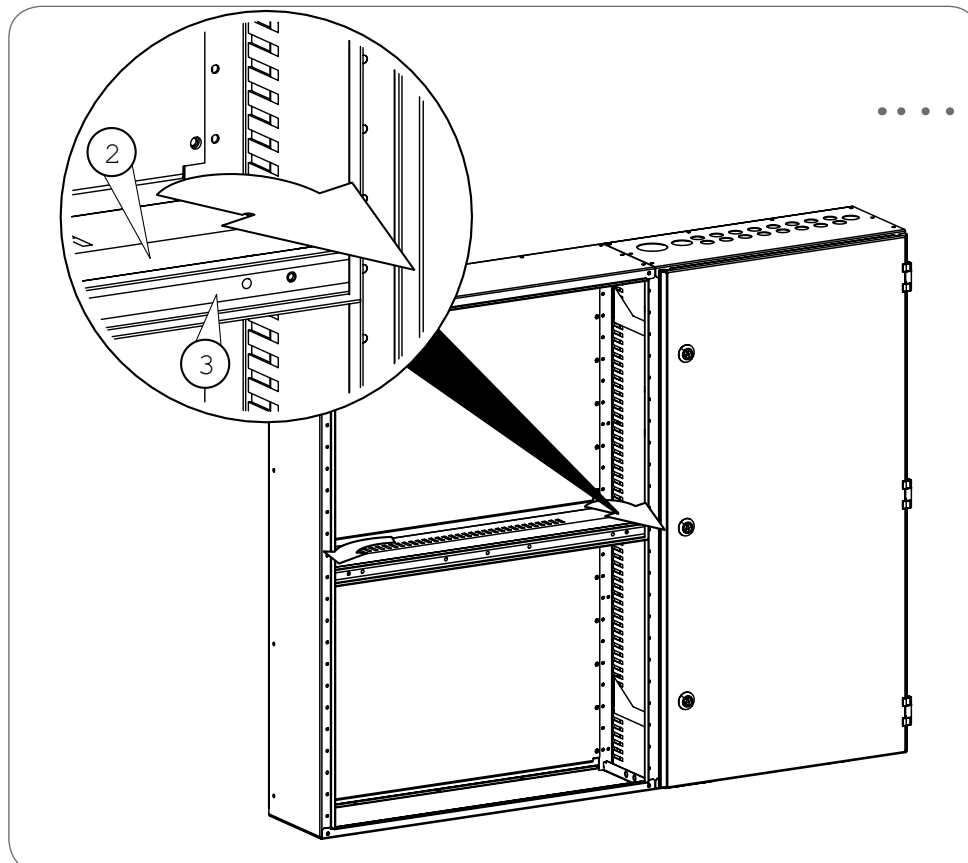
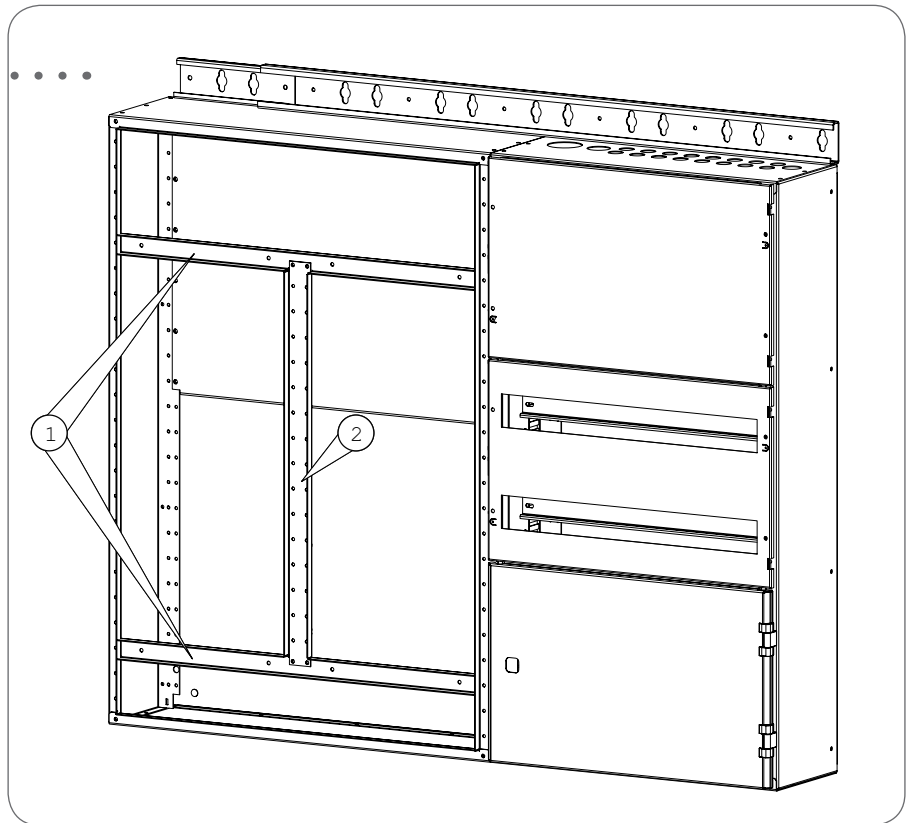

Fig 8.3.2 The drip cover front part (2) is fastened with screws to the front profile and the horizontal intermediate profile (3) that is fixed to the side plate.

Fig 8.3.3 A front profile that divides the field space is installed between two dividing intermediate profiles.



Dividing intermediate profiles

Dividing intermediate profiles can be used, for example, for dividing a 600 mm wide device field into two fields. Dividing intermediate profiles are fastened in the same way as horizontal intermediate profiles. A front profile that divides the field space is installed between two dividing intermediate profiles as shown in Fig. 8.3.3.

Mounting plates

The mounting plates for electric components are fixed to the back plate using assembly screws as shown in Fig. 8.3.4. The mounting plates of both the F- and the E-series systems can be used in the F-series system.

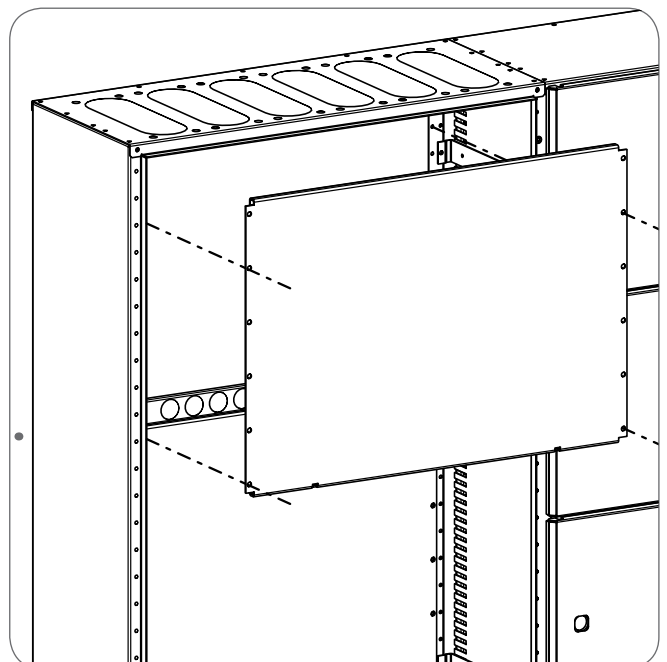

Fig 8.3.4. Installing mounting plates

8.4 Busbar insulator holders and busbar insulators

The busbar insulator holders (1) are used for installing busbars in the cell centre. The busbar insulator holders are fastened to the side plates/front profiles using assembly screws as shown in Fig. 8.4.2.

The busbar insulators are fastened to the busbar insulator holders (3) with screws. For the ends of possible power busbars in an enclosure, busbar insulators (6) and busbar end insulators (1) are installed to insulate the busbars from the metal frame structures as shown in Fig. 8.4.1. The busbar insulators are fastened with either 4.8x9.5mm plate screws or M5x10 assembly screws and the busbar end insulators with, for instance, 5,5x25mm screws.

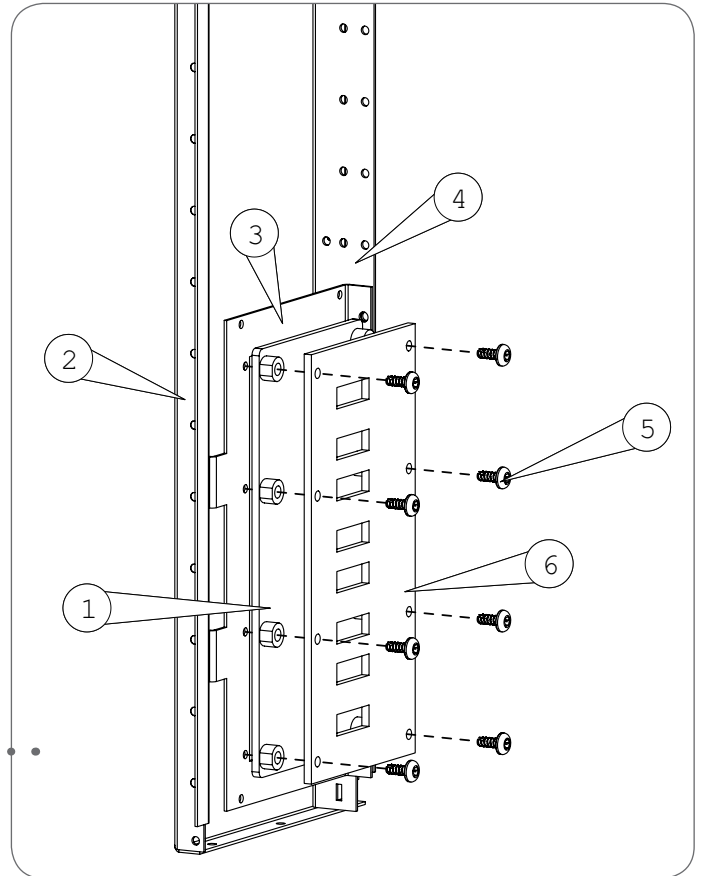

Fig 8.4.1 Installing busbar holder.

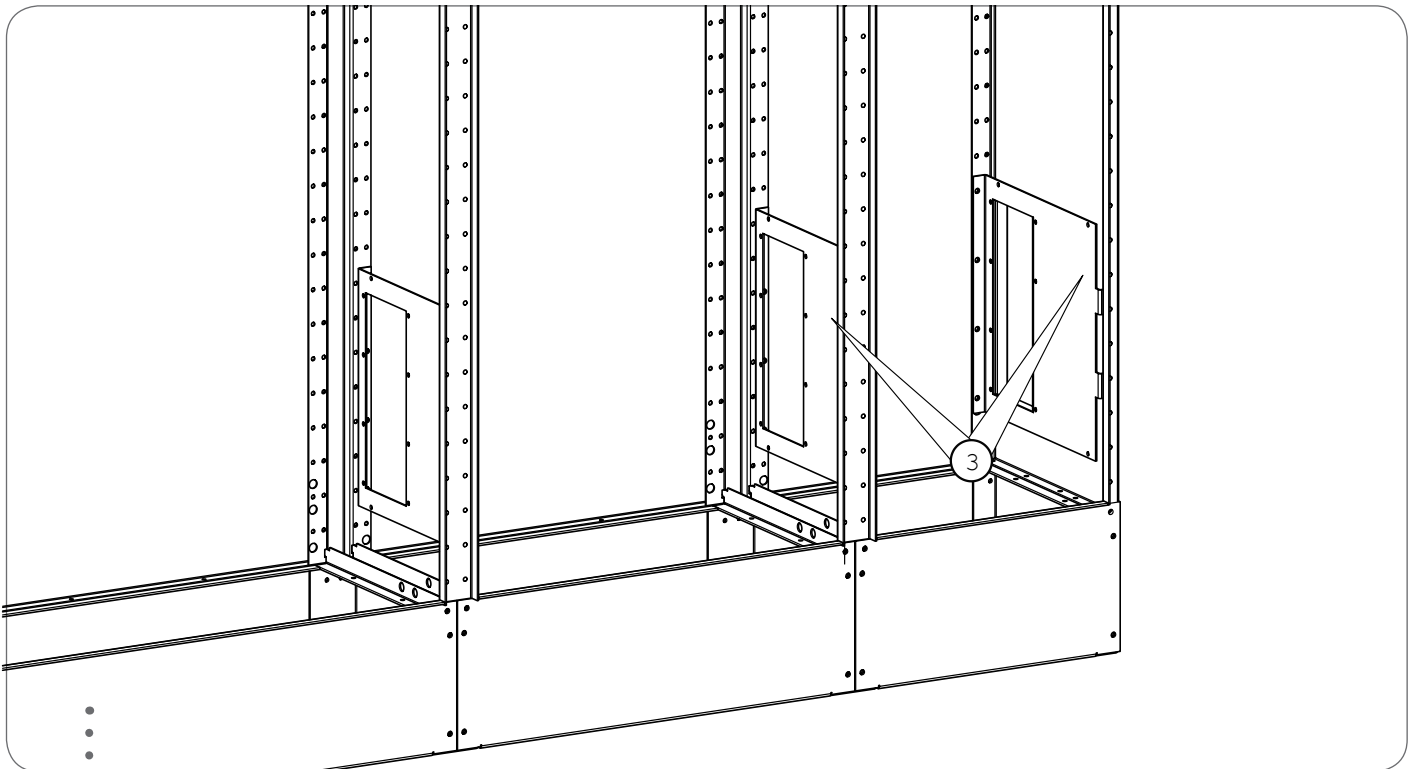

Fig 8.4.2 Installing busbar holders to back plates and front plates.

8.5 Doors

The doors for the F-serie system have preassembled hinges with an opening angle of 160 degrees. The doors are mounted to front profiles or side plates depending on the desired opening direction, see Fig 8.5.1.

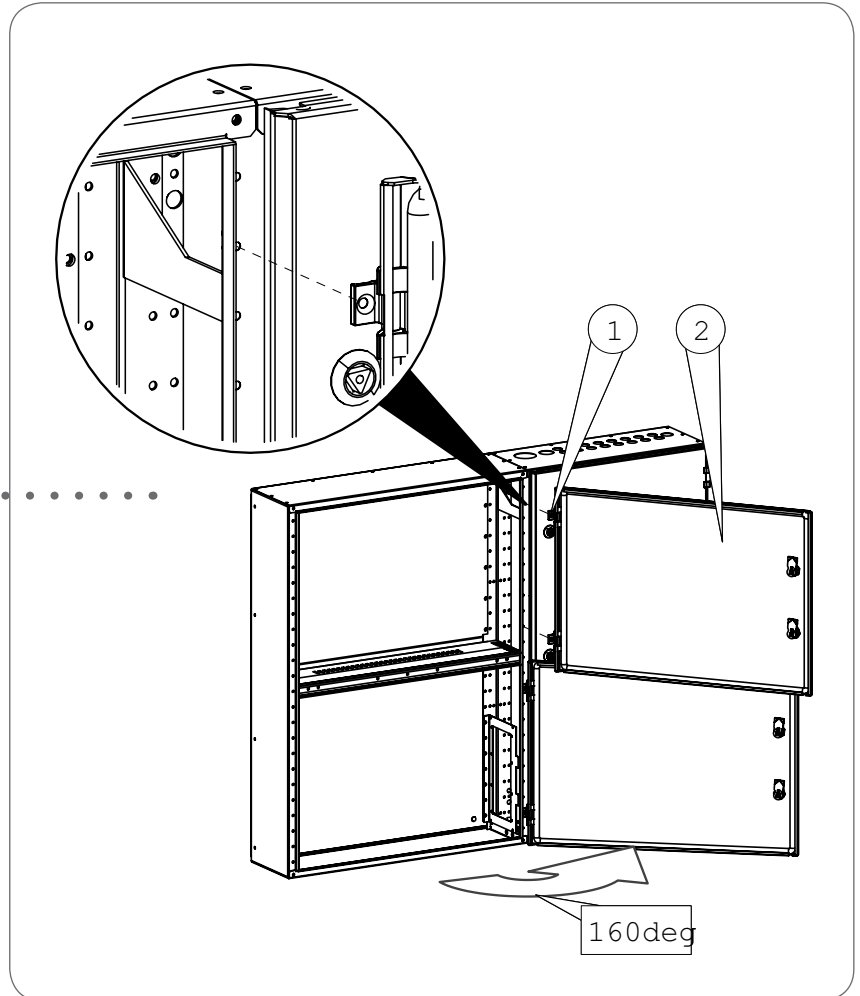

Fig 8.5.1 Doors are mounted to front profiles or side plates. The opening angle for all doors is 160 degrees.

8.6 Intermediate cover system

The intermediate cover system consists of intermediate cover mounting brackets, mountings, and covers. Using the intermediate cover system it is easy to have components with DIN rail mounting neatly behind a door.

Intermediate cover mountings

Intermediate cover mountings (1) are first fastened with screws to intermediate cover mounting brackets (2). Then this mounting set is fastened with assembly screws to the back profile as shown in Fig. 8.6.1

The 17.5 mm spacing of holes in the intermediate cover mountings allows an almost infinite number of different intermediate cover combinations.

Intermediate covers

Intermediate covers (3) are grouped in the desired order to the intermediate cover field and fastened to intermediate cover mountings using intermediate cover hinges (2). At the end(s) of intermediate cover fields it is advisable to use end intermediate covers (1) for covering terminal strips, for instance. Installation of intermediate covers is shown in Fig. 8.6.2

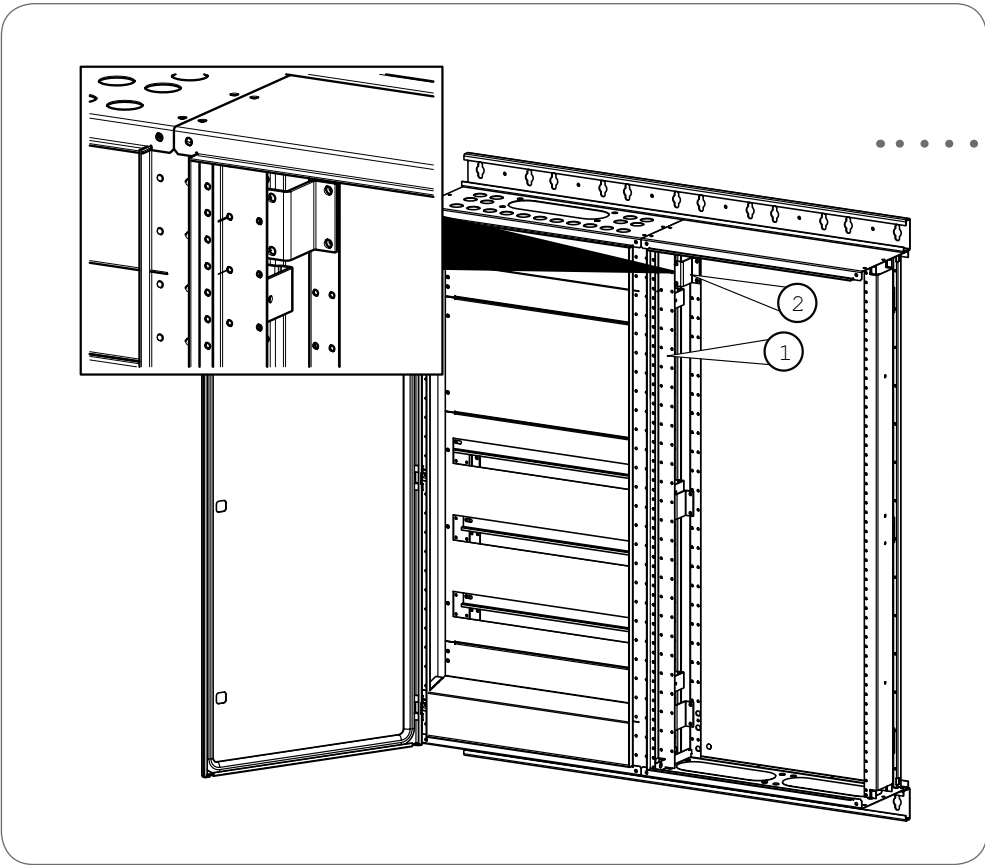

Fig 8.6.1. Intermediate cover mountings and their brackets are assembled together and the assembly is then fastened with screws to the L profiles.

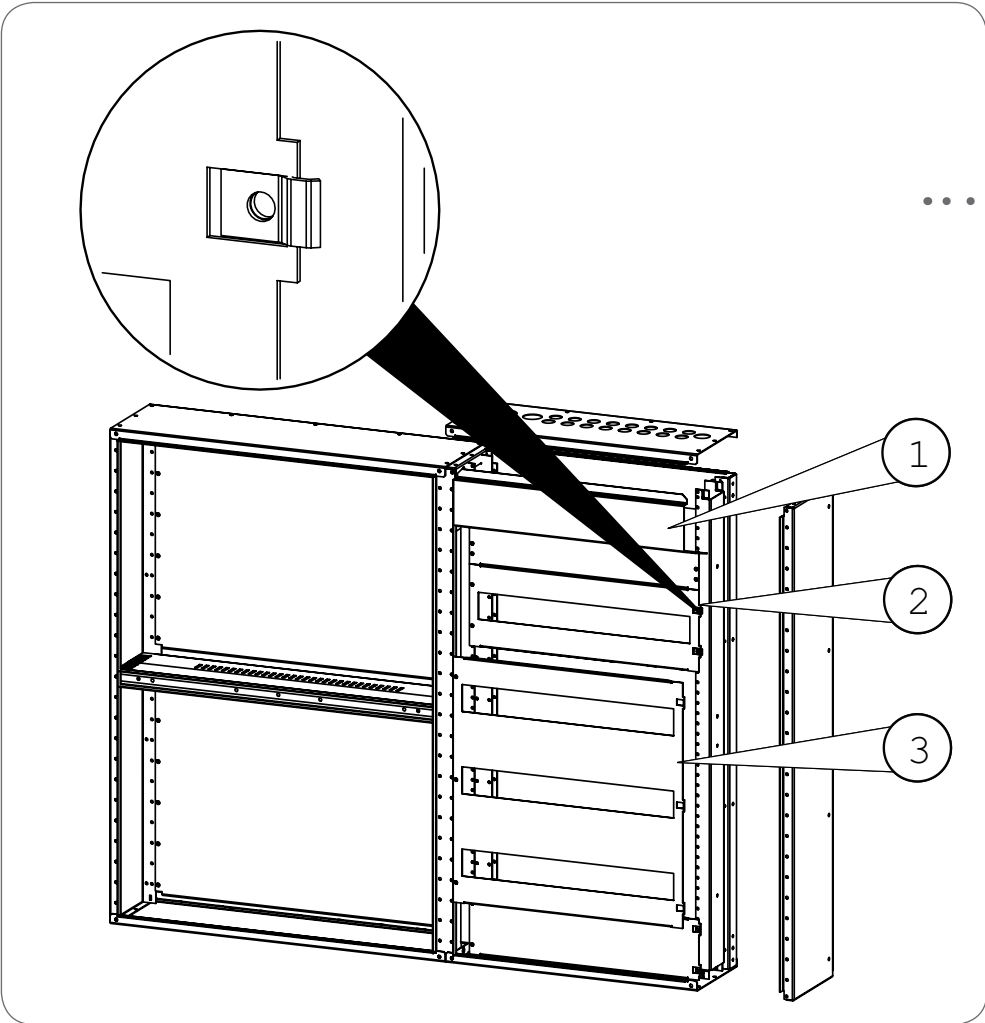

Fig 8.6.2. Intermediate covers are fastened to intermediate cover mountings using intermediate cover hinges and assembly screws.

Installation depth

The installation depth of the intermediate cover system is designed suitable for modular components with DIN rail mounting. The installation depth for modular components is approx. 47.35 mm from DIN rail (1) surface to the rear face of intermediate cover (2). The distance between the intermediate cover surface and the front surface of the door (3) is approx. 72.4 mm as shown in Fig. 8.6.3

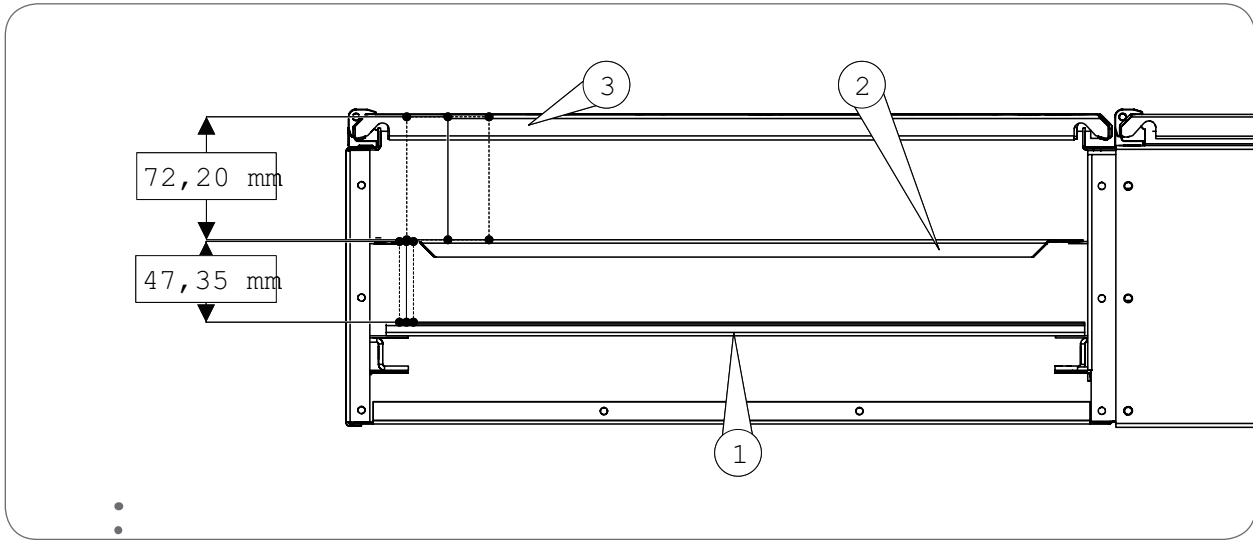

Fig 8.6.3. Sectional view of intermediate cover structure.

8.7 Covers, installation rails and spacers

Covers

The F-series covers (1) are fastened with either 4.8x25mm plate screws or hinges on one side. The covers can also be sealed using the sealing lug (2) of the cover. Installation of covers to the frame structure is shown in Fig. 8.7.1.

Installation rails

Spacers and installation rails are used for components with DIN rail mounting. Installation rails are fastened with screws to the front part of the side plate and front profile as shown in Fig. 8.7.1. The installation rails are dimensioned so that they fit under 280 mm and 420 mm high covers. Figure 8.7.2 shows a sectional view of an application of installation rail and DIN rail. The other parts in Fig. 8.7.2 are side plate, cover, and front profile.

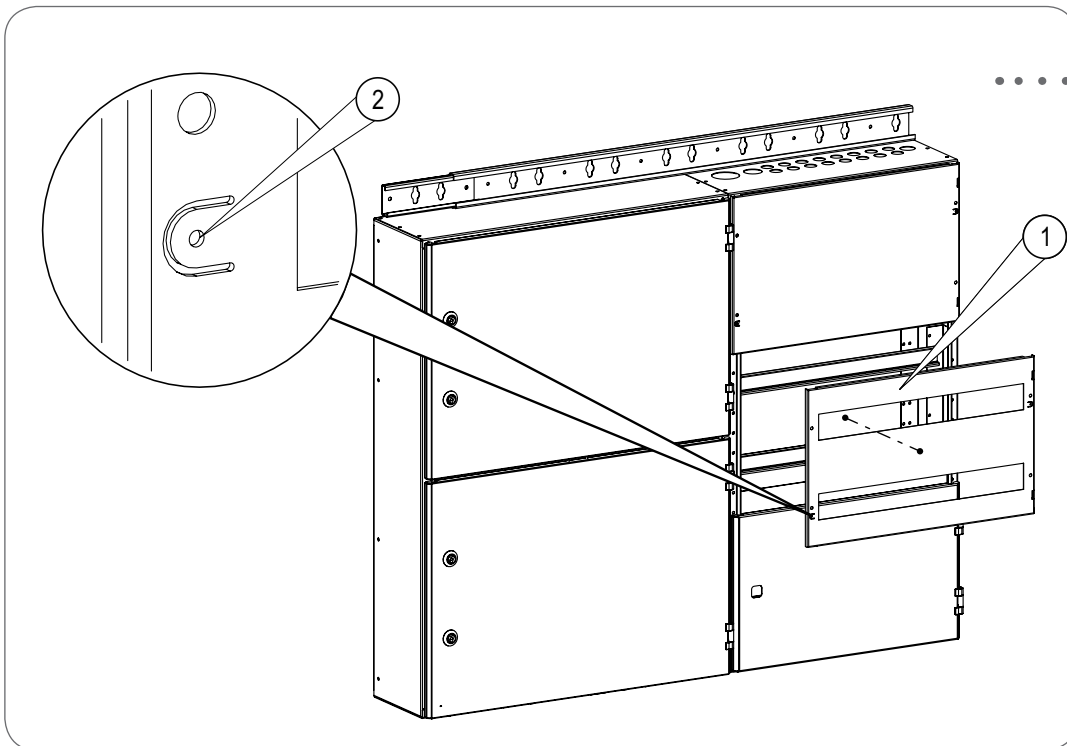

Fig 8.7.1 Installing covers to frame structure. The cover can be fastened using screws or screws and hinges. The cover can also be sealed.

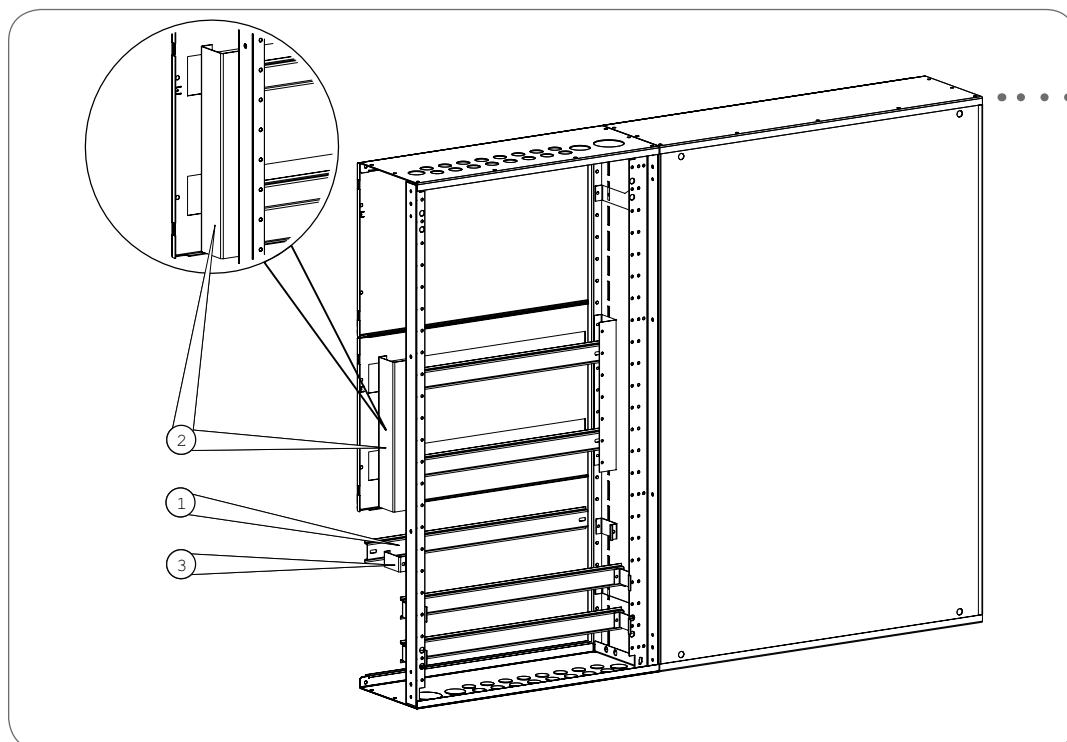

Fig 8.7.2 Fastening installation rail for DIN rails to side plate and front profile.

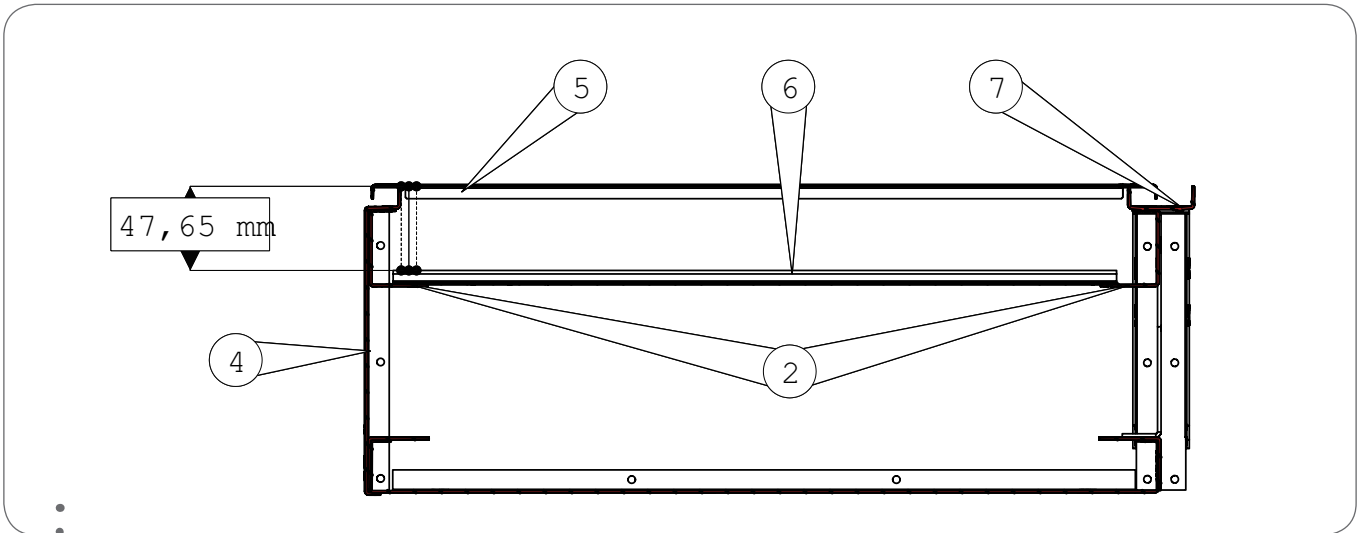

Fig 8.7.3 Sectional view. The distance between DIN rail (6) surface and the back of the cover is 47.65mm.

Compared with spacers, installation rails provide better support for DIN rails and components, but with spacers it may be possible to shorten installation times.

Spacers

By using spacers, you can set the DIN rail distance from the cover suitable to the components. With spacers it

is also possible to bring, for instance, mounting plates forwards from the back plates. Figure 8.7.4 shows the installation of spacers (3) and DIN rails to the back plate. Figure 8.7.5 is a sectional view of the use of spacers showing spacer (3), DIN rail (1), and cover (4).

Fig 8.7.4 Spacers are fastened to back plates, and DIN rails to spacers.

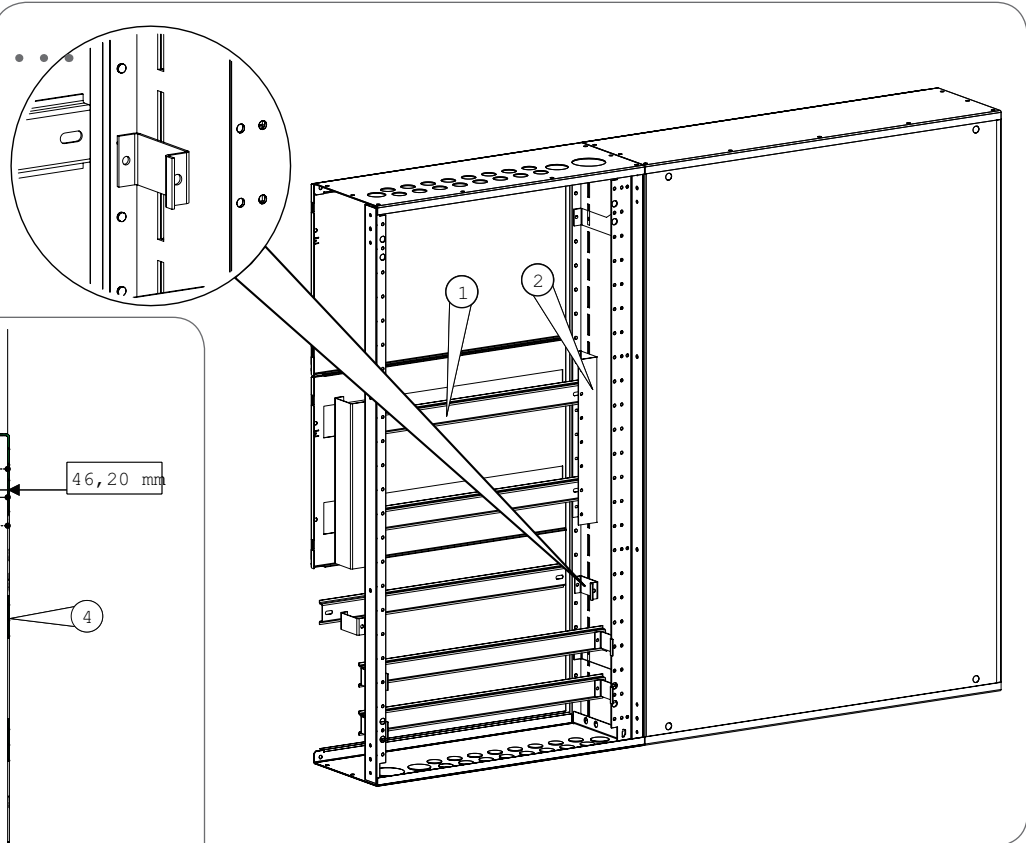

Fig 8.7.5 Sectional view of spacers and DIN rails. The distance between DIN rail surface and the back of the cover is 46.2 mm.

8.8 Touch and finger screens

The use of touch and finger screens is similar to intermediate covers. The DIN rails used for mounting components and the touch screen brackets (2) are fastened in front of spacers. Touch screen plates (1) is fastened with screws or the tabs on the brackets as shown in Fig. 8.8.1.

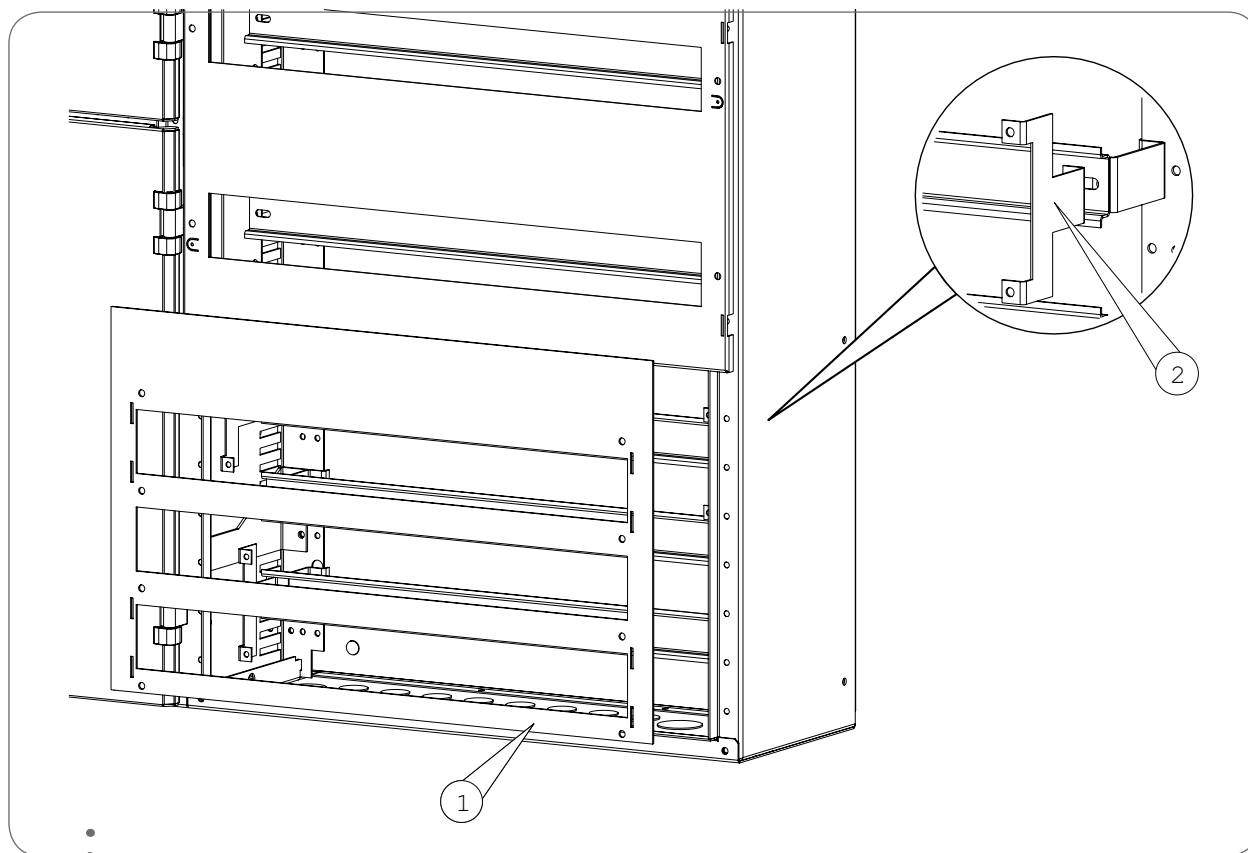

Fig 8.8.1 Installing touch screen plates. Touch screens (1) are fastened using brackets (2) positioned in front of the DIN rails.

8.9 Cover door system

The cover door system can be used, for instance, for easily converting an electric centre enclosure originally provided with touch screening into an enclosure with doors. The cover door system is a frame structure that consists of the actual doors (1), their end pieces (3) and side plates (2), and the corner pieces that reinforce the ends in enclosures with multiple fields. In enclosures with multiple fields you also need latch counterpieces (4) for locking the doors.

The structure of the cover door system is shown in Fig. 8.9.1.

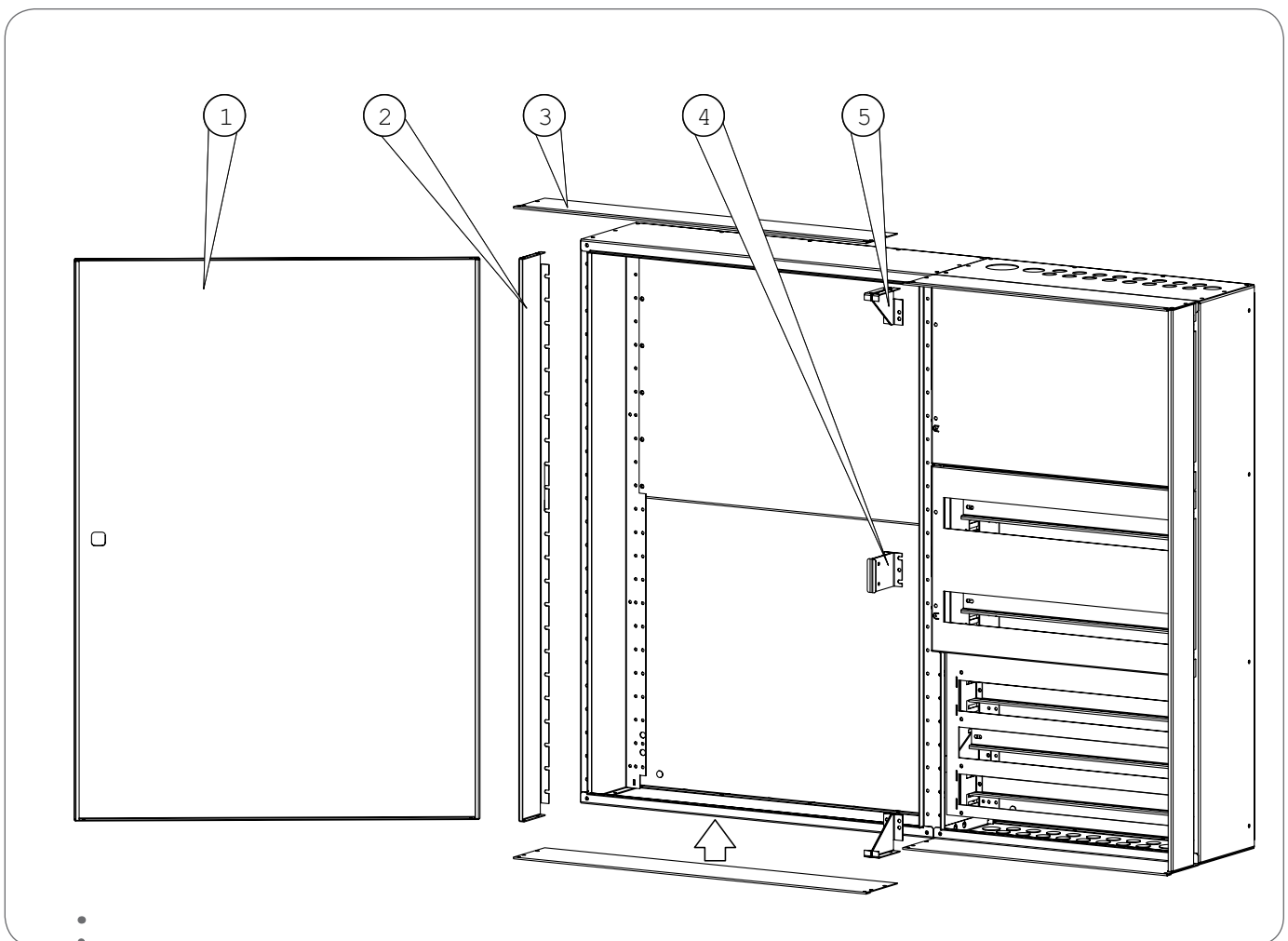

Fig 8.9.1 Peiteovijärjestelmä on kehys, jolla esim. kosketussuojaisiin keskuksiin saadaan jälkepäin lisättyä ovi.

Fixing rails

Fixing rails (2) can be used for fixing a cell centre at the top and bottom to a wall or, for instance, to raising beads. Fixing rails cut to appropriate length is fastened to the enclosure end with screws as shown in Fig. 8.10.1. If necessary, fixing rails can be lengthened using extensions (1).

Attaching brackets

Attaching brackets are used for the same purposes as fixing rails. Attaching brackets (1) are fastened to the enclosure top and bottom ends with assembly screws. Unlike fixing rails, the attaching brackets are mechanical parts with modular dimensions.

Fig 8.10.1 Fixing rails are fastened to end plates. Rails can be connected using extension pieces.

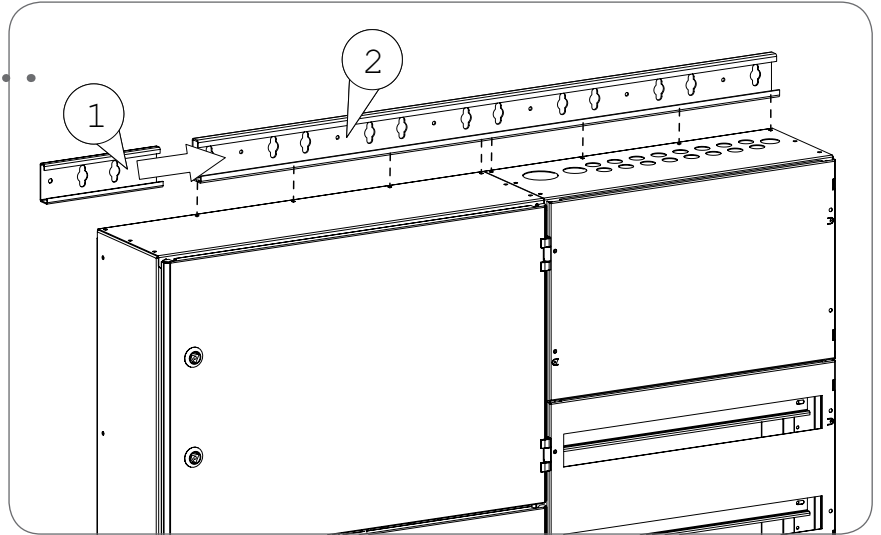
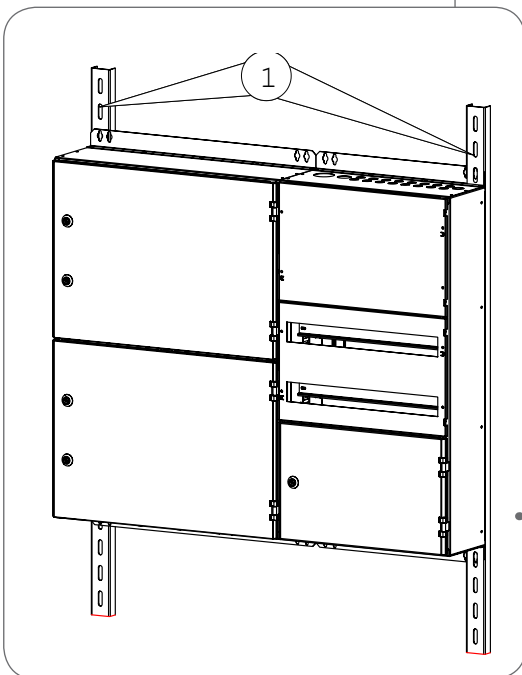
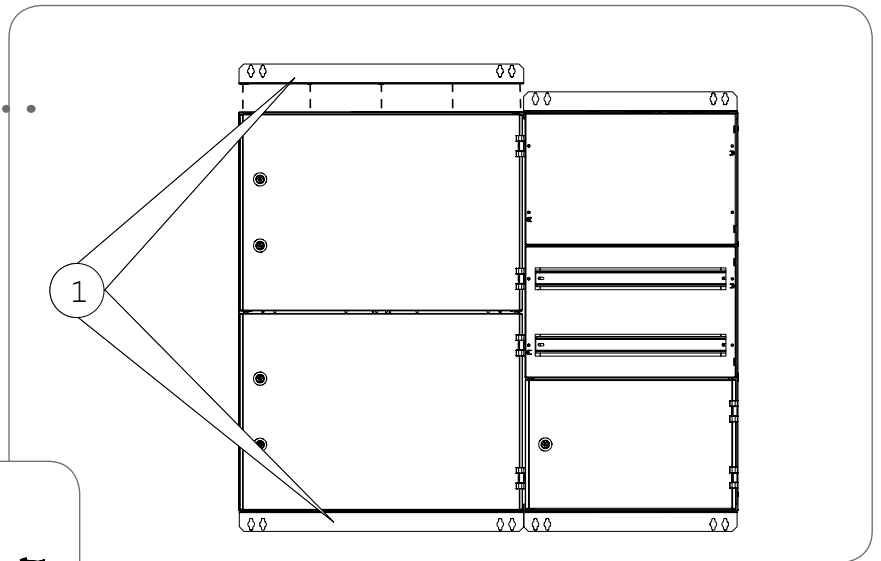

Fig 8.10.2 Attaching brackets are fastened with screws to both ends of enclosure.



Foot balks

Moving an F-serie enclosure can be done by using a transport stand specially designed for this purpose, and it can also be used when assembling the centre. The mechanical parts of the centre are fastened to the transport stand using, for instance, foot balks (1) that can also be used for proving a clearance to the wall.

Fig 8.10.23 Foot balks are fastened to attaching brackets or fixing rails. Foot balks can also be utilized, for instance, when the centre is assembled.

DIN rail brackets

A pair of DIN rail brackets (2) can be used for mounting single DIN rails (1). The brackets can be installed to side plates or front profiles, for instance. The rail is pushed into the slot in the DIN rail bracket as shown in Fig. 8.10.4.

Vertical DIN installation rails

With vertical DIN installation rails (2) DIN rails (1) can be installed vertically in, for instance, the terminal strip space as shown in Fig. 8.10.5. Vertical DIN installation rails can also be used for mounting components in the components compartment when applicable.

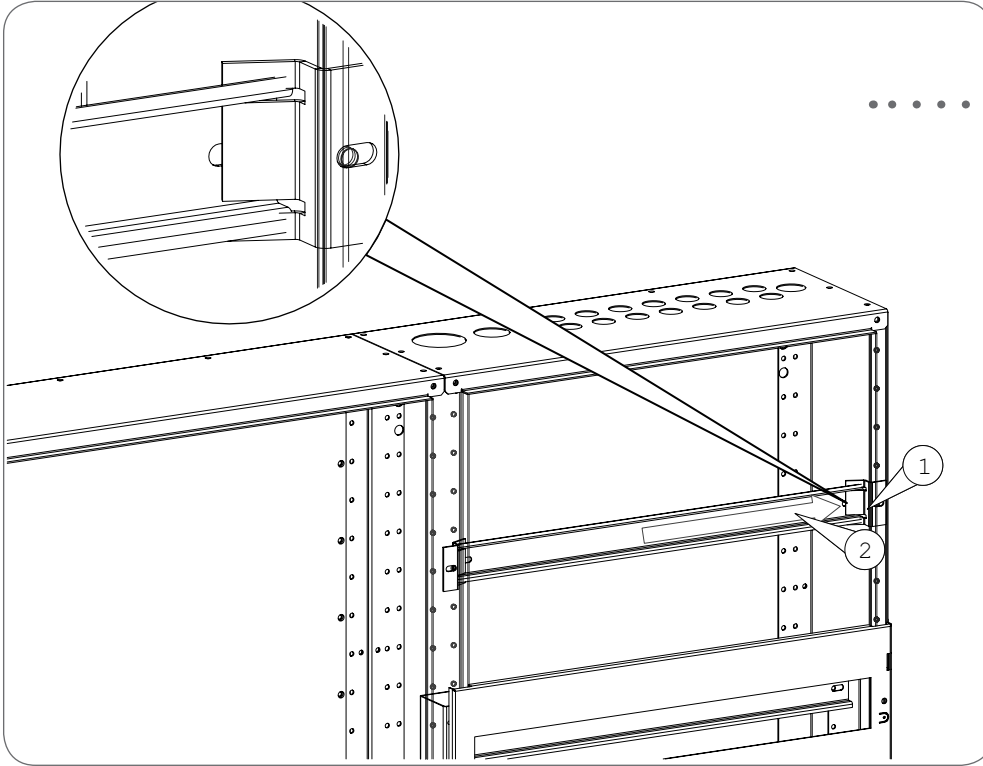

Fig 8.10.4 DIN rails are installed by pushing the rail into the DIN rail bracket.

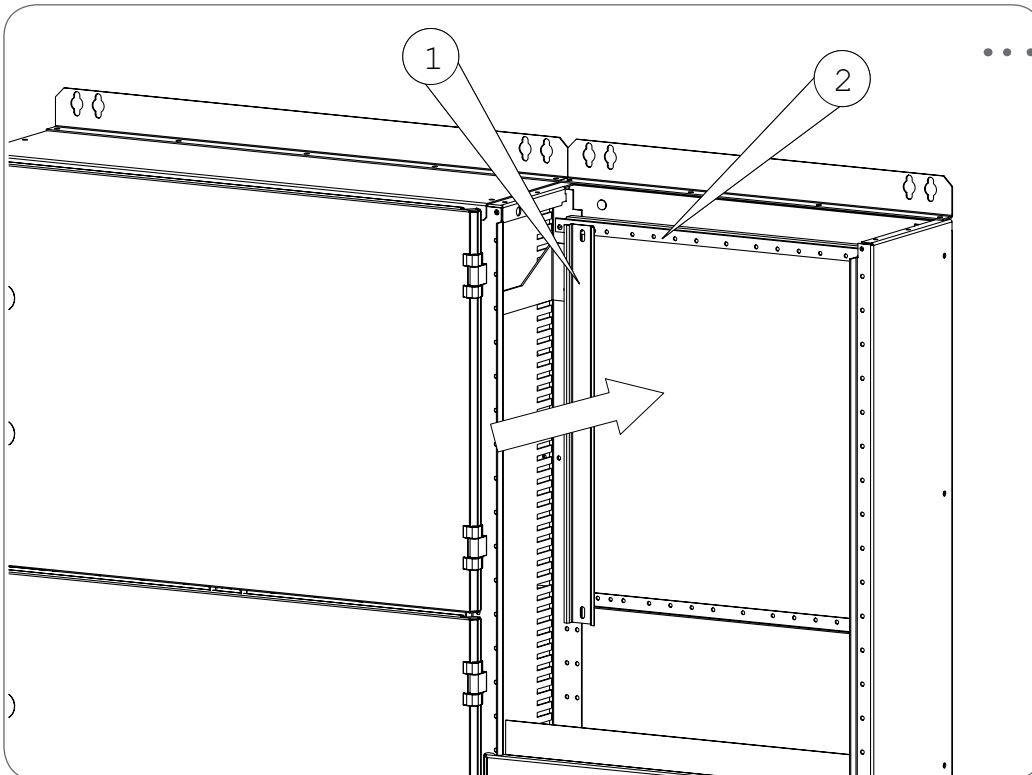

Fig 8.10.5 With vertical DIN installation rails, DIN rails can be mounted vertically.

9 SEALING ENCLOSURE

F-serie cell centres can be built to meet protection class IP55 requirements by using suitable strips and sealants at the joints. Without the use of sealing strips or sealant the protection class is IP20-IP30 depending on the perforations in the front profiles and horizontal intermediate profiles.

9.1 IP rating

Protection class IP40

To reach protection class IP40, sealing strip or sealant is used for sealing the joints between fields and the ends in the enclosure top, and unperforated front profiles/side plates are used.

Protection class IP34

All plate joints shall be provided with 0.8*20 mm sealing strips and the ends of the intermediate profiles shall also be sealed. Sealant is used for sealing the middle joints of the enclosure top and the front side corners of the end plate against the door sealing strip. The edges of possible C flange blanks on the end plates shall be sealed with sealant.

Protection class IP44 (spray protected)

In addition to the above sealing procedures, to reach class IP44 protection, sealant shall also be applied to the vertical joints of the back plates.

Protection class IP55 (watertight)

To reach class IP55 protection, either gluing putty or silicone sealant shall be applied to all joints in parts surrounding the frame structure (including the base). An at least 1.5 mm thick and wide strip of sealant shall be applied to the joint surface so that sealant is squeezed between the plates when the fastening screws are tightened.

The points where sealant shall also be applied are the door openings, i.e. the joints between the side plates and front profiles as well as end plates and intermediate horizontal profiles, see Fig. 9.1.

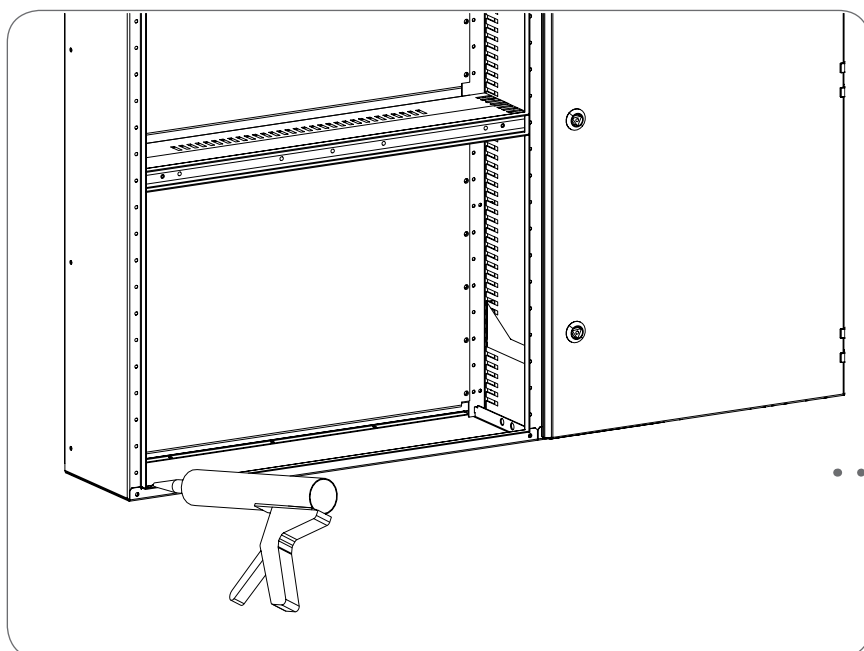

Fig 9.1. Applying sealant to joints between end plates and intermediate horizontal profiles as well as side plates and front profiles.

9.2 Sealing of cell centre parts

In addition to the requirements in Chapter 3.1, the sealing of F-serie centre parts is presented in the following Chapters

Back plates

Sealing strips (2) shall be glued to the long sides of the back plates (1) as shown in Fig. 9.2.

End plates

Of the end plates, the short sides and the rear end facing the back plate shall be sealed according to Figure 9.3.

Side plates

On the side plates (2), sealing strip is attached to the sides facing the back plate and the L profile as shown in Fig. 9.4.

Intermediate profiles

When aiming at very high protection classes (IP34-55) with F-serie NBS enclosures, the joint between intermediate profile and front profile shall be sealed with sealing strip as shown in Fig. 9.4.

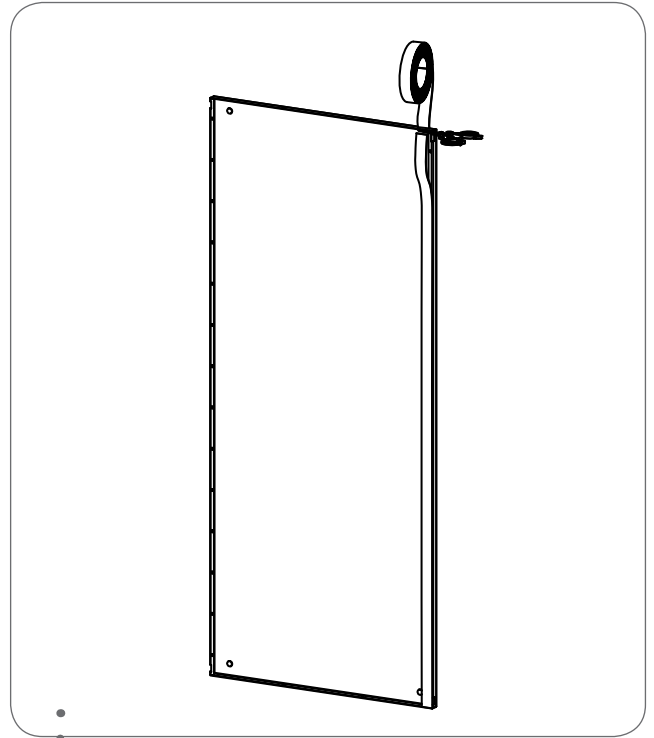

Fig 9.2. Sealing long sides of back plate for F-serie cell centre with sealing strip (50020040 Joint sealing strip 0.8*20 mm).

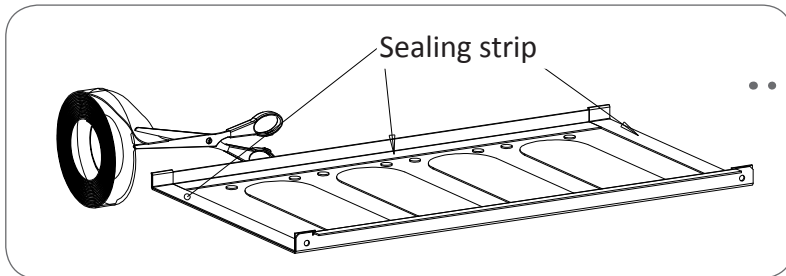

Fig 9.3. Sealing of end plates. Sealing strip is attached to the short sides and rear of the end plates.

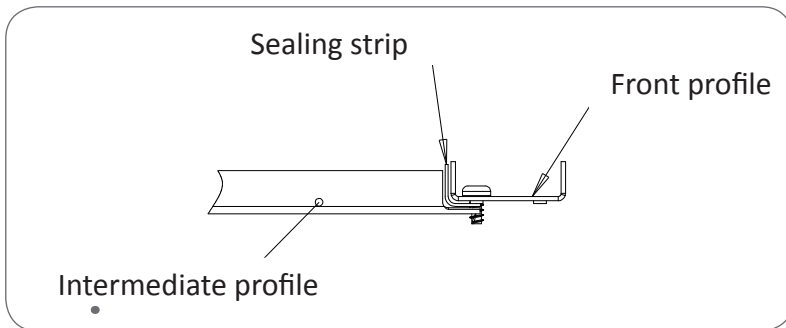

Fig 9.4. Attaching sealing strip to side plate. Sealing strip is attached to the rear part of the side plate.

Several different busbar system alternatives, such as systems built on C- or F- serie flanges, can be used in the F-serie enclosure system. Aluminium busbars were used in the temperature rise and short-circuit tests on the F-serie system, see Table 4.1. The system does not, however, exclude the use of copper busbars that can be dimensioned applying the SFS5556 Standard, see Table 10.2.

F-serie busbar insulators (kute and kuten) shall be used as the insulator elements. With fields more than 450 mm in width intermediate insulators shall be used so that the distance between busbar insulators never exceeds 450 mm. The distance between insulators on vertical busbar systems may not, either, exceed 450 mm, see Fig.10.1.

The short-circuit resistance (I_{pk}) of F-serie centres can be, as necessary, increased by using a shorter insulator distance than 450 mm (=by adding the number of insulators). Added number of insulators has no effect on the thermal short-circuit resistance (I_{cw}).

No separate short-circuit tests have been made for copper busbars. When evaluating the short-circuit protection of copper busbars the short-circuit resistance value for aluminium busbars and insulators can, however, be used.

Fig 10.1. The maximum allowed distance between busbar insulators in the F-serie system is 450mm.

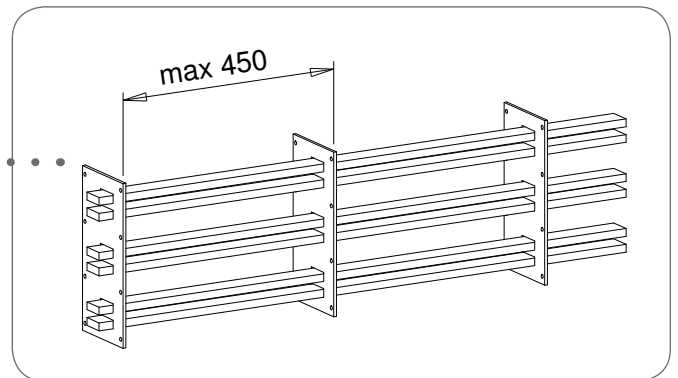

10.1 Horizontal busbars

The horizontal busbar system is installed in the busbar compartment of the F-serie enclosure by using busbar insulator holders and busbar insulators. In the F-serie system, busbar insulators made of polycarbonate (PC) are used, with perforations made for 10x10-10x50 flat bars.

For enclosures with higher protection class than the one given in Tables 4.1 and 4.2 (e.g. IP30 → IP44) the ratings for busbars would be about 20-25% lower than the values given in the Tables.

Rated current I_n [A]	Number of busbars/phase	Al busbar size	Short circuit resistance I_{cw}/I_{pk} [A]*10 ³
400	2	10*20 (1)	17,2/34,1
600	2	10*30 (1)	21,6/42,6
800	2	10*40 (1)	21,6/42,6
1000	2	10*50	24,0/50,4

Table 10.1. The loading tables for aluminium (E-AlMgSi-T6) busbars (conductivity 31,9m/Ωmm²) tested in F-serie enclosures with protection class IP30. The marked (1) busbars have been tested for temperature rise.

Rated current I_n [A]	Number of busbars/phase	Cu busbar size
400	2	5*20
600	2	10*20
800	2	10*30
1000	2	10*40

Table 10.2. Calculated ratings for copper (E-Cu F30) busbars (conductivity 56m/Ωmm²) lying flat in a free space in the F serie cell centre (SFS5556).

10.2 Vertical busbars

Table 10.3 shows the rated currents and the results of the short-circuit and temperature rise tests for vertical busbars in the F-serie NBS cell centre.

According to IEC/EN 61439-1 the busbars (e.g. branch busbars) and conductors between power busbars and

the operating unit feed connections as well as the devices within operating units can be dimensioned field-specifically on the basis of the loads caused by a short-circuit upstream of the short-circuit protector. In other words, the short-circuit resistance of vertical and branch busbars need not be equal to the value for horizontal busbars.

Rated current I_n [A]	Number of busbars/phase	Al busbar size	Short circuit resistance I_{cw}/I_{pk} [A]*10 ³
250	2	10*10	7,5/12,8
400	2	10*20	7,5/12,8
630	2	10*20	7,5/12,8
800	2	10*30	23,0/48,3
1000	2	10*40	24,0/50,4

Table 10.3. Loading tables for vertical aluminium busbars. Temperature rise tests have been carried out for the marked (1) busbars.

10.3 Equipment earthing

The purpose of equipment earthing is to protect the user against the effects of possible faults in the cell centre or in the external circuit feeding the cell centre. The equipment earthing circuit of the cell centre consists of separate protective conductors or conductive structures or both.

10.3.1 Protective earthing of frame

For protective earthing, the F-serie enclosures have holes that can be used for providing protective earthing of the frame. Using M8 screws you can connect max. one 70mm² protective conductor of copper. At this point you must make sure that the connector used provides a sufficient contact area to the frame.

Cross-section of phase conductor S [mm ²]	Min. cross-section of corresponding protective conductor (PE, PEN) S_p [mm ²]
$S \leq 16$	S
$16 < S \leq 35$	16
$35 < S \leq 400$	$S/2$
$400 < S \leq 800$	200
$800 < S$	$S/4$

Table 10.4. Cross-sectional area (IEC/EN 61439-1) of protective earth conductor (PE, PEN).

According to IEC/EN 61439-1 the cross section of a protective conductor can be calculated from the equation

$$S_p = \frac{\sqrt{I^2 t}}{k} \tag{4.1}$$

The equation is used for calculating the cross section for a protective conductor capable of sustaining the thermal load caused by a current of short duration. Table 4.5 contains some protective conductor cross sections calculated using equation 4.1.

Installing PE busbar

The PE busbar is installed in F-serie centres in the front part of the equipment compartment using PE busbar holders or to F serie/C flange with rail. The PE busbar is connected using connectors that are suitable for PEN, PE, N, main potential equalizing and frame protective earthing connections according to SFS 154 (e.g. YKPEN and YKOL connectors).

Rated thermal current resistance of cell centre I_{cw} [A]x10 ³	PVC insulated copper conductor Cu [mm ²]	Aluminium busbar 10x30 mm
5	35	1
6	50	1
10	70	1
12,5	2x50	1
16	2x70	1
20	2x70	1
25	3x70	2
32	4x70	2
40	4x70	2
50	5x70	3
63	7x70	3

Table 10.5. Protective earthing of frame according to rated thermal current resistance (I_{cw}).

10.3.2 Protective earthing of covers and doors

Protective earthing of covers and doors to the frame structure is provided through the direct contact of their unpainted rear parts and the contact surfaces of their fastening screws. Components with max. 16 A rated current can be mounted to doors without separate protective earthing conductor. For higher currents, doors must be provided with separate protective earthing using a conductor that is connected to the door through either a screw and nut connection or a protective earthing screw welded to the door.

10.4 Connecting of busbars

The power busbar system is installed in the F-serie enclosure between the back profile and the front side of the front profile/side plate using busbar insulator holders and busbar insulators. The F-serie cell centre has been tested using horizontal and vertical busbars of aluminium with their rated values given in Chapters 10.2 and 10.3.

To connect conductors to the busbars and busbars to each other you can use various types of busbar connectors (see EI-parts Oy's product catalogue, for example).

SFS 154 provides comprehensive information on connectors for aluminium conductors and connections of aluminium busbars. The Table below gives tightening torques for aluminium connections.

Screw size	M6	M8	M10	M12	M16
Tightening torque [Nm]	6...9	15...22	30...44	50...75	120...190

Table 10.6. Tightening torques for Al connection screws.

Attachment of the Feeder bar and bus bar

The feeder bars are attached to the horizontal power bus bars f. ex. like shown in the figure 10.2. A suitable piece of A1-bar is added between the feeder bus bars. The bars are joined together with a pair of screw and nut and with the help of various connections and plate washers.

Installing the upright and horizontal bus bars

The upright and horizontal bus bars are fixed together if needed by using the bus bar connections YKG, fig. 10.3.

When making the connections you must make sure that the requirements on making connections presented in the SFS handbook 154, Chapter 7.1.3 are complied with. For example, the mating surfaces of the connection must be deoxidized and the cleaned surfaces protected with connection grease.

Transport break

Any break points made into the cell centre and power busbar system should be located at a cable field to make reconnecting of busbars easier. For example, YKG 51/120 aluminium profiles and M10 screws and nuts are used for the connection as shown in Fig. 10.4.

When reconnecting, the busbar parts are matched together. The connecting pieces are placed symmetrically over the joint, and the screws are tightened to the correct torque (Table 10.6).

- 1. zincd M10 hex. head screw (class 8.8)
- 2. special washer YKG 28.3 M10
- 3. horizontal power busbars
- 4. connecting piece YKG 51/80(/100)
- 5. feed busbars
- 6. SFS 3738 pressure washer
- 7. zincd M10 nut (class 8)
- 8. SFS3737 conical spring washer
- 9. spacer piece, e.g. of 10x30 Al busbar

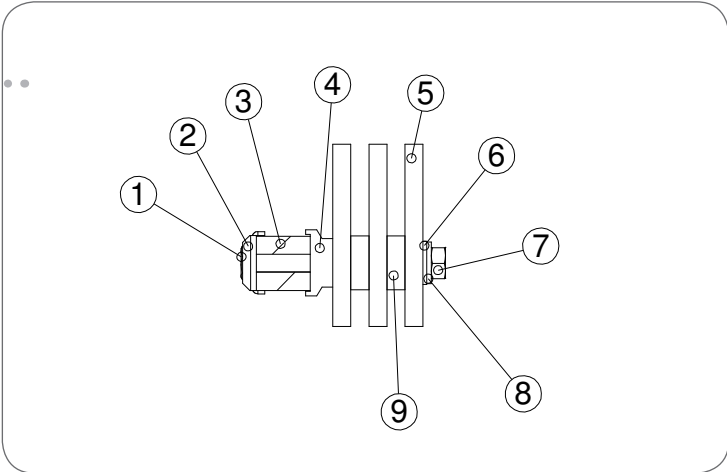

Fig 10.2. Connecting feed and horizontal power busbars together.

- 1. zincd M10 nut (8)
- 2. SFS3737 conical spring washer
- 3. vertical busbars
- 4. connecting piece YKG 51/30
- 5. horizontal busbars
- 6. special washer YKG 28.3 M10
- 7. zincd washer YKG 44
- 8. zincd hex. head screw M10 (8.8)

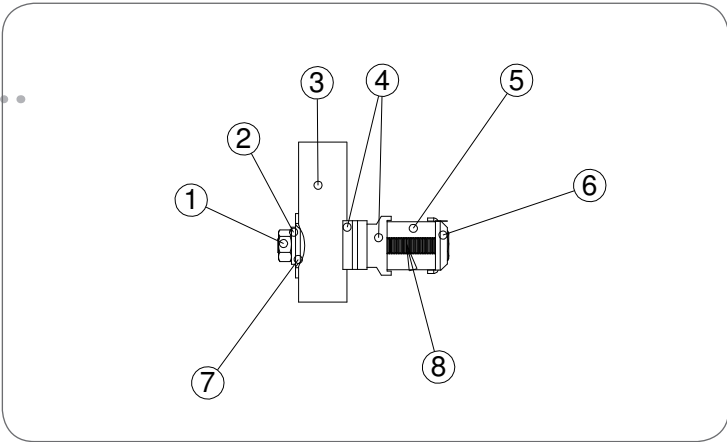

Fig 10.3. Connecting vertical and horizontal busbars using YKG busbar connectors.

- 1. power busbar
- 2. YKG 51/120
- 3. zincd M10 hex. head screw (8.8)
- 4. SFS 3738 pressure washer
- 5. zincd hex. nut (8)
- 6. SFS3737 conical spring washer
- 7. SFS 3738 pressure washer

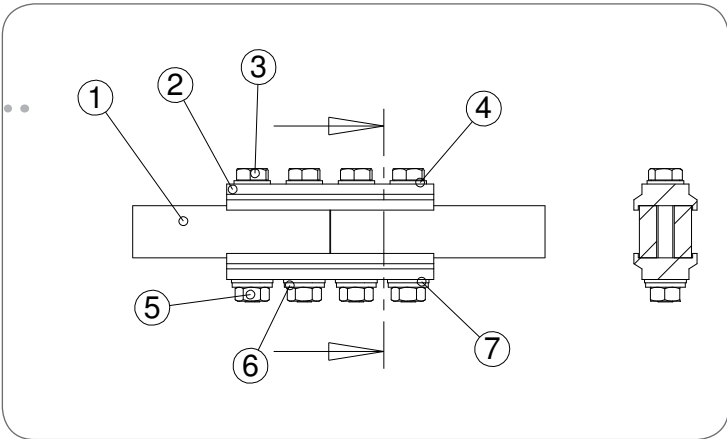

Fig 10.4. Connecting of busbars at a transport break. The busbars are connected using connecting pieces of aluminium (e.g. YKG 51/120), M10 screws and nuts, and various washers.

1.1 OTHER INFORMATION

The F-serie cell centre structure is designed for distribution, control, and automation centres as well as enclosures for electronic equipment.

Compliance

When assembling centres using the F-serie system you should ensure with, for instance, piece tests (standard series IEC/EN 61439, Chapters 8.1.2 and 8.3) that the structural solutions of the delivered centres will comply with the type tested centre and meet the requirements of the standards that for the basis for certification.

In addition to the examples in these instructions the requirements and regulations in the IEC/EN 61439 Standard shall be observed when assembling the power busbar system as well as the whole distribution centre. When using the structure you should also consider the various product standards according to which the final enclosed product shall be made.

When assembling the structure you shall utilize the specified screws, lifting eyes, washers, hinges, the components used in tests or corresponding components, and follow the assembly and operating instructions provided by the centre mechanics supplier. The dimensioning of the instrument mountings on the mounting plates complies with the SFS 2529 Standard. Instrument spaces comply with the SFS 5601 Standard.

Manufacturer reserves the right to technical changes.

Compatibility

The parts of the electric centre enclosure systems manufactured by Finelcomp Oy are primarily compatible with one another, for instance, the doors and mounting plates are compatible with all systems.

Independency of components

The frame structure and fastening mechanics are designed so that the commonest and standardized electric and mechanical components (e.g. components mounted to DIN rails, feedthrough flanges) are easy to install to the structure. The structures of the F-serie NBS cell centre are not component-dependent, in other words, you can use the components of any components manufacturer.

Safety distances

In the design of the F-serie cell centre attention has been paid on the safety distances between live parts and the conductive parts of the frame. Both surface and air gap distances in the F-serie cell centre are at least 7 mm.

Static loads

Depending on the size, the mounting plates for F-serie are made of either 1.5 or 2.0 mm hot-galvanized steel sheet. The structure and the mounting plates can be statically loaded by 2 kg/dm² of mounting plate with components fastened to the mounting plate. In this case, the number of mounting plate screws shall be at least equal to the mass of the component divided by two (2), however, not less than four (4) mounting screws.

Components can be mounted to doors and covers as necessary. The maximum mass mounted to doors is 0.5 kg/dm² but, nevertheless, not more than 6 kg per hinge in addition to the door's own weight. The allowed masses fastened to screw-mounted covers are 0.25 kg/dm² but, nevertheless, not more than 1 kg per cover mounting screw.

12 TECHNICAL DATA

General

The F-serie NBS enclosure system complies with the requirements in the Standards IEC/EN 61439-1, IEC/EN 61439-3 and IEC/EN 62208. The product complies with the essential safety requirements set for CE marking by the Low Voltage Directive 2006/95/EC.

Insulating voltage U_i	1000V
Rated voltage U_n	690V
Rated current I_n	<1000A
Thermal short-circuit resistance I_{cw}	17,2-60kA/1s
Dynamic short-circuit resistance I_{pk}	25,6-132kA
Protection classes	IP20-IP55
Impact strength	IK09
Material	
frame parts	hot-galvanized steel sheet 275MAC
busbar insulators	polycarbonate, PC
Nominal dimensions	
depth	80, 160, 250, and 320mm
field widths	300, 450, 600, and 750mm
Surface treatment	powder paint, must be ordered separately

1. ENCLOSURE STRUCTURE

1.1 Base Components

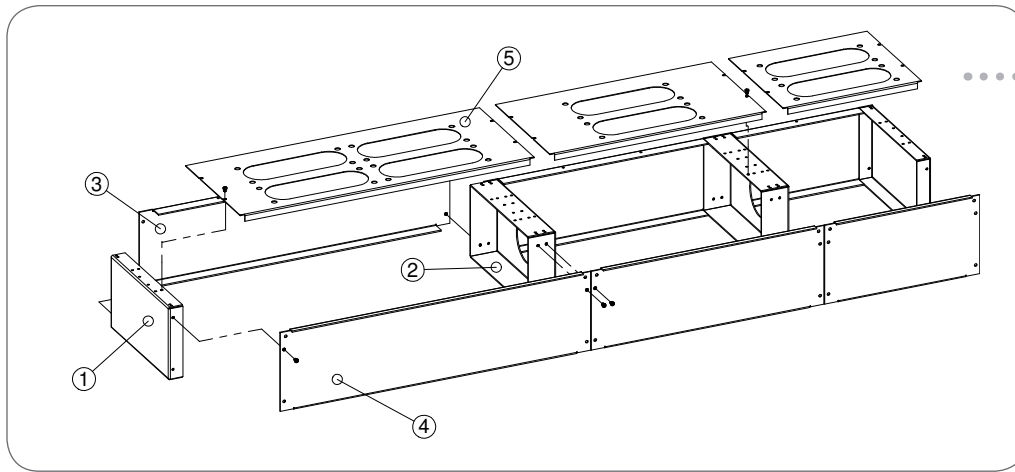

1. Base end
2. Base divider
3. Base back plate
4. Base front plate
5. Base bottom plate

1. Base ends

Code	Description	Depth mm (A)	Height mm (C)	Colour
50529051	Base end 16	160	140	zn
50529052	Base end 25	250	140	zn
50529053	Base end 32	320	140	zn
50029211	Base end 164	160	40	zn
50029212	Base end 254	250	40	zn
50029213	Base end 324	320	40	zn

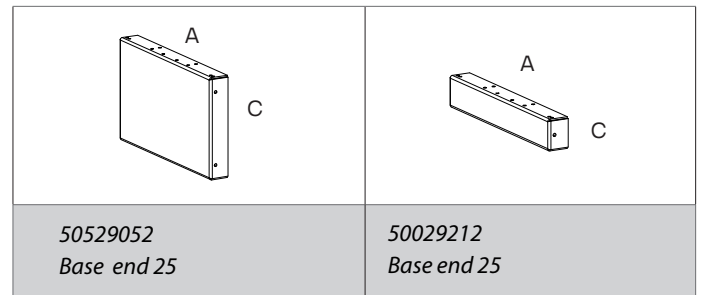

2. Base dividers

Code	Description	Depth mm (A)	Height mm (C)	Colour
50529054	Divider 16	160	140	zn
50529055	Divider 25	250	140	zn
50529056	Divider 32	320	140	zn
50029214	Divider 164	160	40	zn
50029215	Divider 254	250	40	zn
50029216	Divider 324	320	40	zn

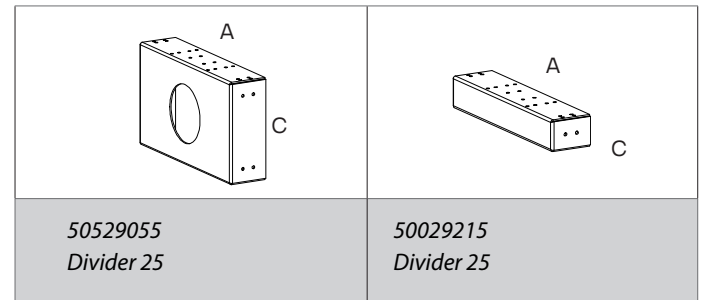

3. Base back plates

Code	Description	Width mm (B)	Height mm (C)	Colour
50529069	Base back plate 20	200	140	zn
50529057	Base back plate 30	300	140	zn
50529058	Base back plate 45	450	140	zn
50529059	Base back plate 60	600	140	zn
50529050	Base back plate 75	750	140	zn
50529086	Base back plate 90	900	140	zn
50029220	Base back plate 240	200	40	zn
50029217	Base back plate 340	300	40	zn
50029218	Base back plate 440	450	40	zn
50029219	Base back plate 640	600	40	zn
50029221	Base back plate 740	750	40	zn

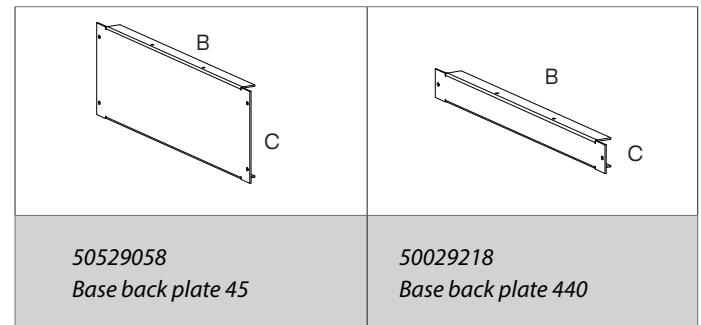

4. Base front plate

Code	Description	Width mm (B)	Height mm (C)	Colour
50528064	Base front plate 20	200	140	zn
50528065	Base front plate 30	300	140	zn
50528066	Base front plate 45	450	140	zn
50528067	Base front plate 60	600	140	zn
50528068	Base front plate 75	750	140	zn
50528069	Base front plate90	900	140	zn
50528070	Base front plate30 IP30	300	140	zn
50528071	Base front plate45 IP30	450	140	zn
50528072	Base front plate60 IP 30	600	140	zn
50528073	Base front plate75 IP30	750	140	zn
50528115	Base front plate 204	200	40	zn
50528101	Base front plate 304	300	40	zn
50528102	Base front plate 454	450	40	zn
50528103	Base front plate 604	600	40	zn
50528109	Base front plate 754	750	40	zn

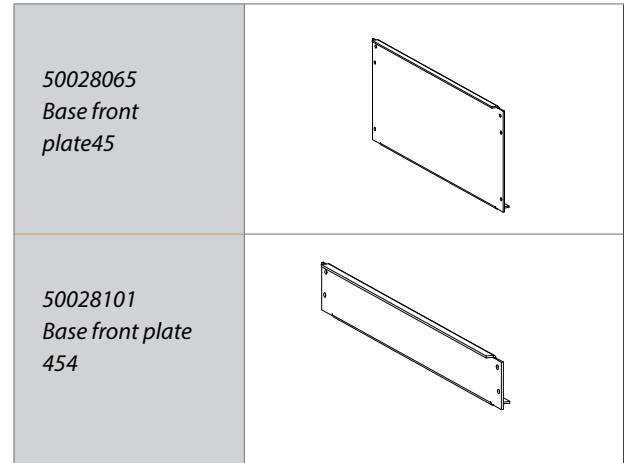

5. Base bottom plate

Code	Description	Depth mm (A)	Width mm (C)	Colour
50029066	Base bottom plate 130	160	300	zn
50029067	Base bottom plate 145	160	450	zn
50029068	Base bottom plate 160	160	600	zn
50029079	Base bottom plate 220	250	200	zn
50029063	Base bottom plate 230	250	300	zn
50029064	Base bottom plate 245	250	450	zn
50029065	Base bottom plate 260	250	600	zn
50029084	Base bottom plate 275	250	750	zn
50029094	Base bottom plate 320	320	200	zn
50029060	Base bottom plate 330	320	300	zn
50029061	Base bottom plate 345	320	450	zn
50029062	Base bottom plate 360	320	600	zn
50029083	Base bottom plate 375	320	750	zn

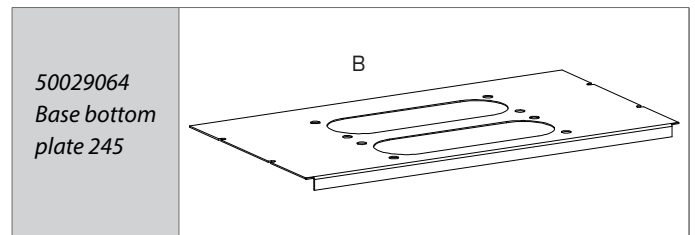

1.2 Bottom plates

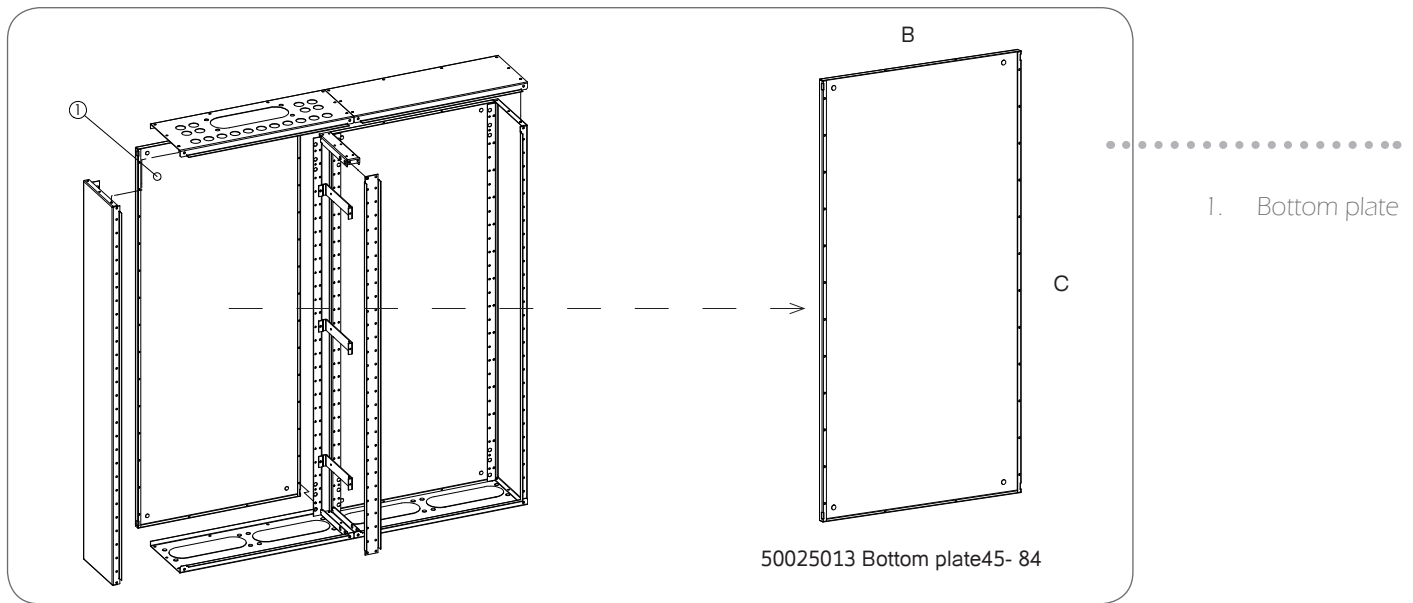

1. Bottom plate

Code	Description	Width mm (B)	Height mm (C)	Colour
50025009	Bottom plate 20-140	200	140	zn
50025045	Bottom plate 20-168	200	168	zn
50025000	Bottom plate 20-196	200	196	zn
50025008	Bottom plate 30- 28	300	280	zn
50025001	Bottom plate 30- 42	300	420	zn
50025002	Bottom plate 30- 56	300	560	zn
50025041	Bottom plate 30- 70	300	700	zn
50025003	Bottom plate 30- 84	300	840	zn
50025046	Bottom plate 30- 98	300	980	zn
50025004	Bottom plate 30-112	300	1120	zn
50025005	Bottom plate 30-140	300	1400	zn
50025006	Bottom plate 30-168	300	1680	zn
50025007	Bottom plate 30-196	300	1960	zn
50025010	Bottom plate 45- 28	450	280	zn
50025011	Bottom plate 45- 42	450	420	zn
50025012	Bottom plate 45- 56	450	560	zn
50025042	Bottom plate 45- 70	450	700	zn
50025013	Bottom plate 45- 84	450	840	zn
50025044	Bottom plate 45- 98	450	980	zn
50025014	Bottom plate 45-112	450	1120	zn
50025015	Bottom plate 45-140	450	1400	zn
50025016	Bottom plate 45-168	450	1680	zn
50025017	Bottom plate 45-196	450	1960	zn

Code	Description	Width mm (B)	Height mm (C)	Colour
50025020	Bottom plate 60- 28	600	280	zn
50025021	Bottom plate 60- 42	600	420	zn
50025022	Bottom plate 60- 56	600	560	zn
50025043	Bottom plate 60- 70	600	700	zn
50025023	Bottom plate 60- 84	600	840	zn
50025047	Bottom plate 60- 98	600	980	zn
50025024	Bottom plate 60-112	600	1120	zn
50025025	Bottom plate 60-140	600	1400	zn
50025026	Bottom plate 60-168	600	1680	zn
50025027	Bottom plate 60-196	600	1960	zn
50025050	Bottom plate 75- 28	750	280	zn
50025051	Bottom plate 75- 42	750	420	zn
50025052	Bottom plate 75- 56	750	560	zn
50025053	Bottom plate 75- 70	750	700	zn
50025054	Bottom plate 75- 84	750	840	zn
50025048	Bottom plate 75- 98	750	980	zn
50025034	Bottom plate 75-112	750	1120	zn
50025035	Bottom plate 75-140	750	1400	zn
50025036	Bottom plate 75-168	750	1680	zn
50025037	Bottom plate 75-196	750	1960	zn

1.3. Side plates

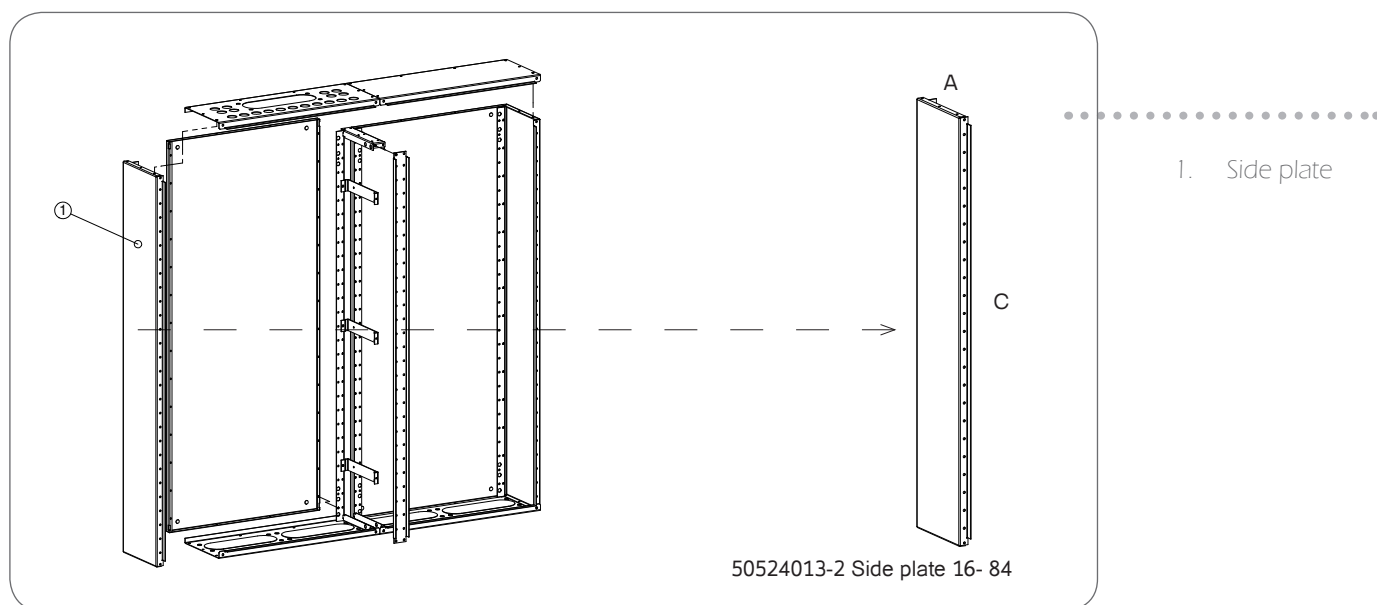

1. Side plate

Code	Description	Depth mm (A)	Height mm (C)	Colour
50524035-2	Side plate 8- 14	80	140	RAL7035
50524031-2	Side plate 8- 28	80	280	RAL7035
50524001-2	Side plate 8- 42	80	420	RAL7035
50524002-2	Side plate 8- 56	80	560	RAL7035
50524033-2	Side plate 8- 70	80	700	RAL7035
50524003-2	Side plate 8- 84	80	840	RAL7035
50524008-2	Side plate 8- 98	80	980	RAL7035
50524004-2	Side plate 8-112	80	1120	RAL7035
50524005-2	Side plate 8-140	80	1400	RAL7035
50524006-2	Side plate 8-168	80	1680	RAL7035
50524007-2	Side plate 8-196	80	1960	RAL7035
50524032-2	Side plate 16- 28	160	280	RAL7035
50524011-2	Side plate 16- 42	160	420	RAL7035
50524012-2	Side plate 16- 56	160	560	RAL7035
50524034-2	Side plate 16- 70	160	700	RAL7035
50524013-2	Side plate 16- 84	160	840	RAL7035
50524041-2	Side plate 16- 98	160	980	RAL7035
50524014-2	Side plate 16-112	160	1120	RAL7035
50524015-2	Side plate 16-140	160	1400	RAL7035
50524016-2	Side plate 16-168	160	1680	RAL7035
50524017-2	Side plate 16-196	160	1960	RAL7035

Code	Description	Depth mm (A)	Height mm (C)	Colour
50524037-2	Side plate 25- 42	250	420	RAL7035
50524038-2	Side plate 25- 56	250	560	RAL7035
50524039-2	Side plate 25- 70	250	700	RAL7035
50524018-2	Side plate 25- 84	250	840	RAL7035
50524023-2	Side plate 25- 98	250	980	RAL7035
50524019-2	Side plate 25-112	250	1120	RAL7035
50524020-2	Side plate 25-140	250	1400	RAL7035
50524021-2	Side plate 25-168	250	1680	RAL7035
50524022-2	Side plate 25-196	250	1960	RAL7035
50524043-2	Side plate 32- 56	320	560	RAL7035
50524040-2	Side plate 32- 84	320	840	RAL7035
50524042-2	Side plate 32-112	320	1120	RAL7035
50524088-2	Side plate 32-140	320	1140	RAL7035
50524089-2	Side plate 32-168	320	1680	RAL7035
50524036-2	Side plate 32-196	320	1960	RAL7035

1.4. Extension side plates

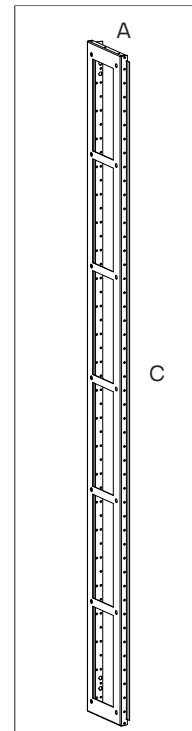
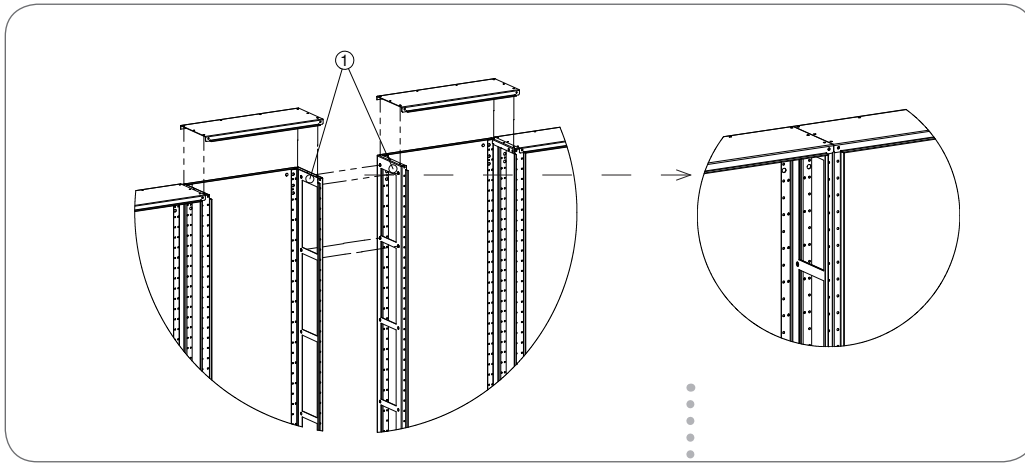

50524013-2
Extension side plate 16- 168

1. Extension side plates

1. Extension side plates

Code	Description	Depth mm (A)	Height mm (C)	Colour
50524024	Extension side plate 16-168	160	1680	zn
50524025	Extension side plate 16-196	160	1960	zn
50524028	Extension side plate 25-140	250	1400	zn
50524026	Extension side plate 25-168	250	1680	zn
50524027	Extension side plate 25-196	250	1960	zn

1.5. End plates

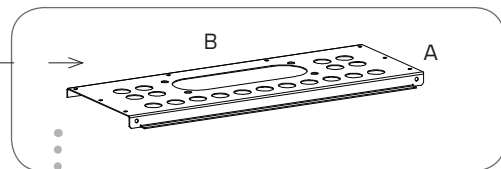
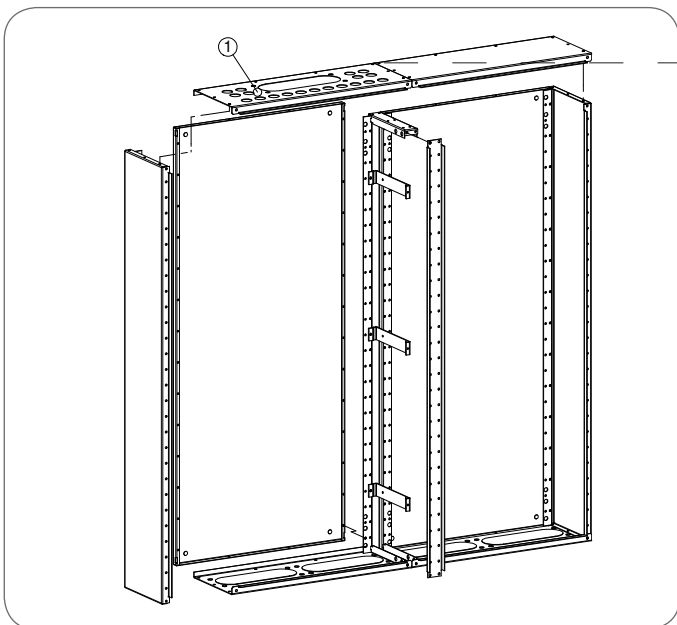

1. End plates

1. End plates

Code	Description	Depth mm (A)	Width mm (C)	Colour
50522999-2	End plate 20-25	250	200	RAL7035
50523000-2	End plate 20-25 C	250	200	RAL7035
50522998-2	End plate 20-32 C	320	200	RAL7035
50523001-2	End plate 30- 8	80	300	RAL7035
50523002-2	End plate 30- 8 T	80	300	RAL7035
50523044-2	End plate 30- 8 1CA	80	300	RAL7035

Code	Description	Depth mm (A)	Width mm (C)	Colour
50523050-2	End plate 30-8 1KL	80	300	RAL7035
50523003-2	End plate 30-16	160	300	RAL7035
50523004-2	End plate 30-16 TC	160	300	RAL7035
50523008-2	End plate 30-32	320	300	RAL7035

1. End plates continues (see layout figures in page 59)

Code	Description	Depth mm (A)	Width mm (C)	Colour
50523007-2	End plate 30-32 C	320	300	RAL7035
50523011-2	End plate 45- 8	80	450	RAL7035
50523012-2	End plate 45- 8 T	80	450	RAL7035
50523047-2	End plate 45-8 1CA	80	450	RAL7035
50523045-2	End plate 45- 8 2CA	80	450	RAL7035
50523051-2	End plate 45-8 2KL	80	450	RAL7035
50523013-2	End plate 45-16	160	450	RAL7035
50523014-2	End plate 45-16 1C	160	450	RAL7035
50523015-2	End plate 45-16 2C	160	450	RAL7035
50523020-2	End plate 45-16 P	160	450	RAL7035
50523016-2	End plate 45-16 TC	160	450	RAL7035
50523058-2	End plate 45-32	320	450	RAL7035
50523019-2	End plate 45-32 C	320	450	RAL7035
50523028-2	End plate 45-32 4C	320	450	RAL7035
50523021-2	End plate 60- 8	80	600	RAL7035
50523022-2	End plate 60- 8 T	80	600	RAL7035
50523046-2	End plate 60- 8 2CA	80	600	RAL7035

Code	Description	Depth mm (A)	Width mm (C)	Colour
50523052-2	End plate 60-8 3KL	80	600	RAL7035
50523023-2	End plate 60-16	160	600	RAL7035
50523028-2	End plate 60-16 2C	160	600	RAL7035
50523024-2	End plate 60-16 T/2C	160	600	RAL7035
50523057-2	End plate 60-32	320	600	RAL7035
50523027-2	End plate 60-32 C	320	600	RAL7035
50529196-2	End plate 60-32 EP	320	600	RAL7035
50523029-2	End plate 60-32 4C	320	600	RAL7035
50523033-2	End plate 75- 8	80	750	RAL7035
50523036-2	End plate 75-8 T	80	750	RAL7035
50523034-2	End plate 75-16	160	750	RAL7035
50523030-2	End plate 75-16 3C	160	750	RAL7035
50523059-2	End plate 75-32	320	750	RAL7035
50523035-2	End plate 75-32 C	320	750	RAL7035
50523043-2	End plate 75-32 6C	320	750	RAL7035

2. Special end plates (see layout figures in page 59)

Code	Description	Colour
50529170-2	Special end plate feedthrough plate	RAL7035

3. Special end plates (see layout figures in page 59)

Code	Description	Width mm (B)	Colour
50529191-2	Special end plate 30-16 EP	300	RAL7035
50529181-2	Special end plate 30-25 EP	300	RAL7035
50529192-2	Special end plate 45-16 EP	450	RAL7035
50529193-2	Special end plate 60-16 EP	600	RAL7035
50529185-2	Special end plate 30-32 EP	300	RAL7035
50529186-2	Special end plate 60-32 EP2	600	RAL7035
50529187-2	Special end plate 60-32 EP	600	RAL7035

	Colour
50529180-2 Special end plate covering plate	RAL7035
50529189-2 Special end plate covering plate 32 EP	RAL7035
50529190-2 Special end plate covering plate 16 EP	RAL7035

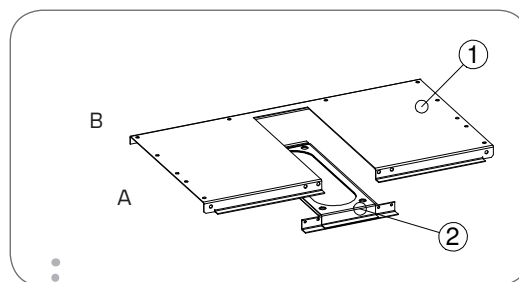

1. 50529172-2 Special end plate 45-25 E
2. 50529170-2 Special end plate feedthrough plate

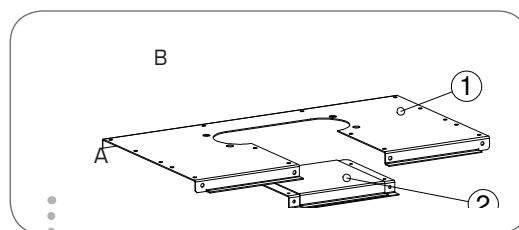

1. 50529182-2 Special end plate 45-25 EP
2. 50529180-2 Special end plate covering plate

END PLATES, ENCLOSURE-/CELL STRUCTURE

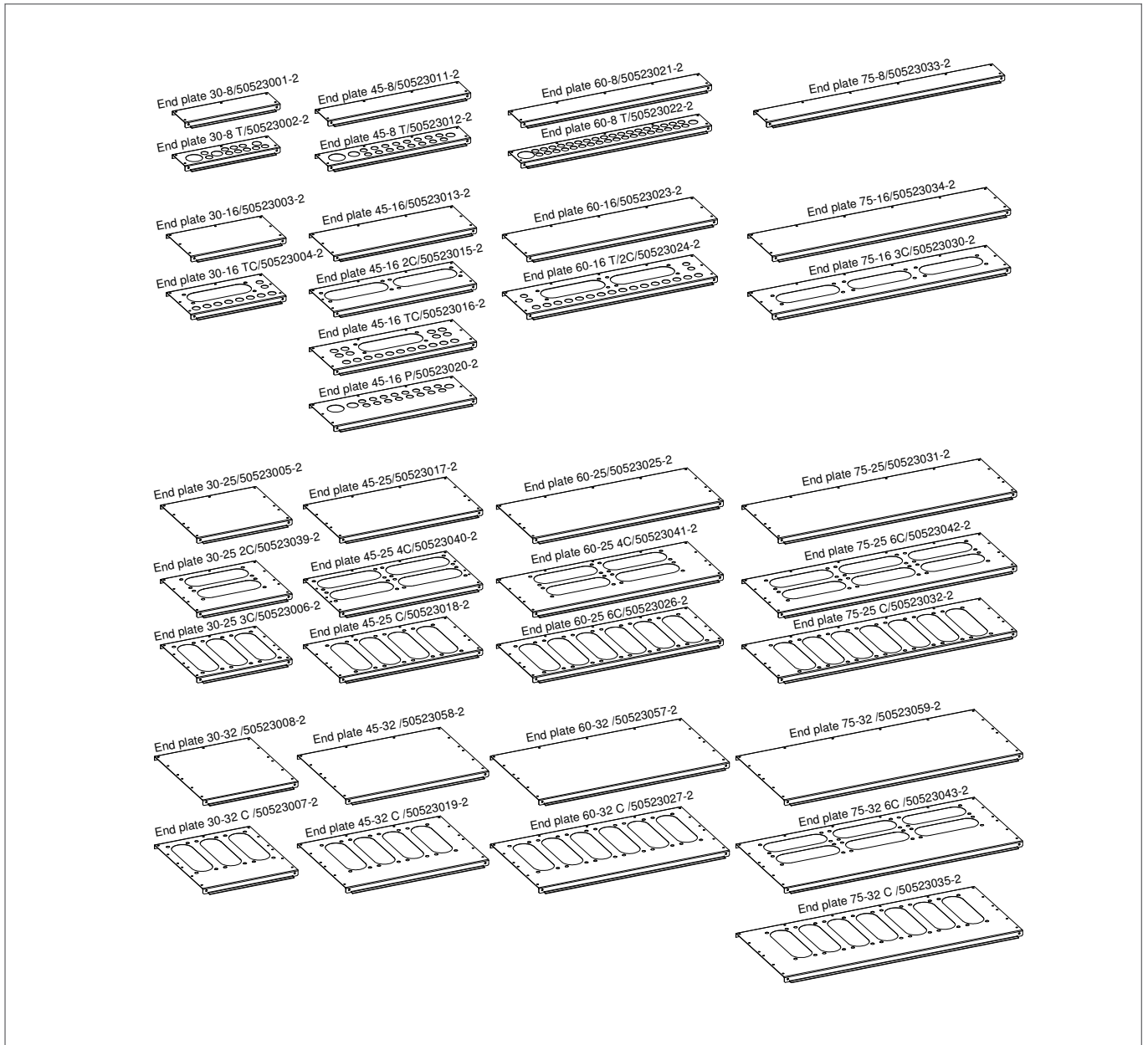

SPECIAL END PLATES

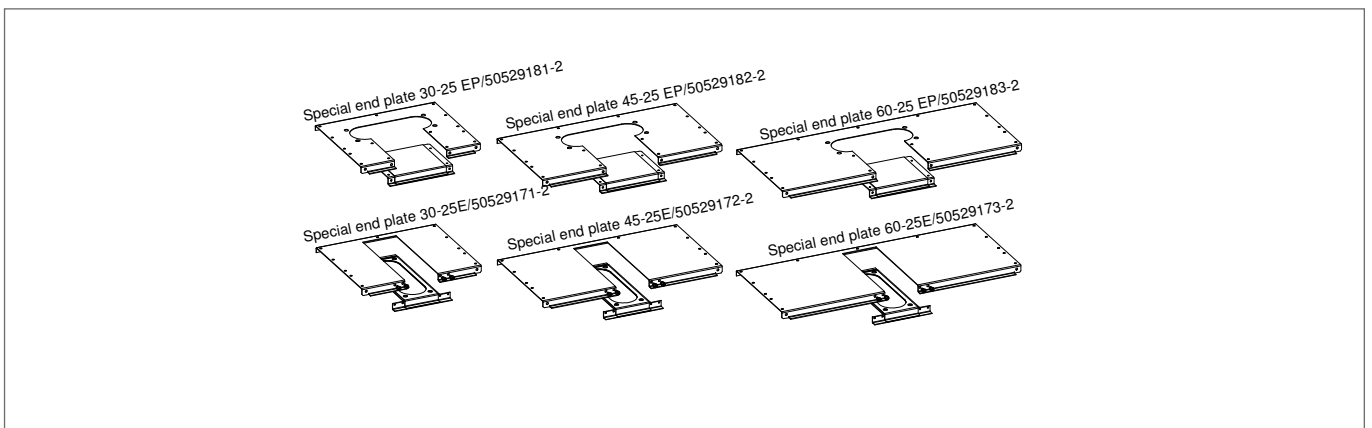

1.6. Front- and back profiles

1. Front profiles

Code	Description	Height mm (B)	Colour
50526013	Front profile 28	280	zn
50526014	Front profile 42	420	zn
50526015	Front profile 56	560	zn
50526012	Front profile 70	700	zn
50526016	Front profile 84	840	zn
50526016R	Front profile 84, hole IP20	840	zn
50526021	Front profile 98	980	zn
50526021R	Front profile 98, hole IP20	980	zn
50526017	Front profile 112	1120	zn
50526017R	Front profile 112, hole IP20	1120	zn
50526018	Front profile 140	1400	zn
50526018R	Front profile 140, hole IP20	1400	zn
50526019	Front profile 168	1680	zn
50526019R	Front profile 168, hole IP20	1680	zn
50526020	Front profile 196	1960	zn
50526020R	Front profile 196, hole IP20	1960	zn
50526022	Front profile 224	2240	zn

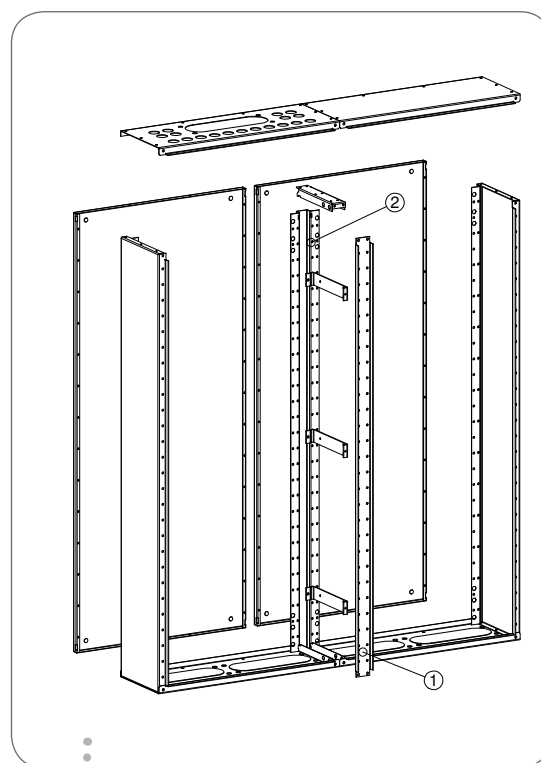

- 1. Front profile
- 2. Back profile

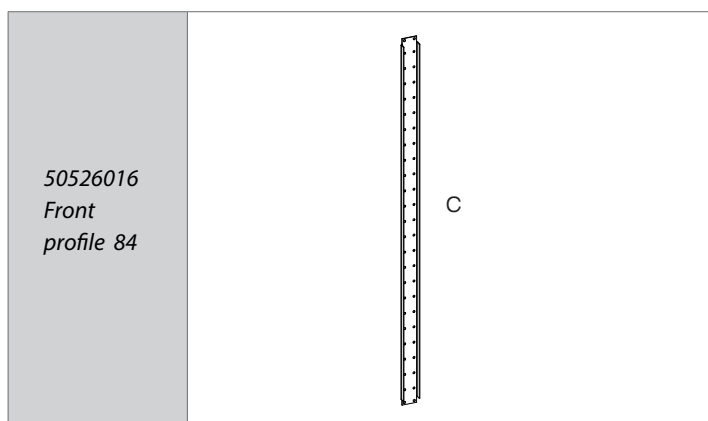

2. Back profiles

Code	Description	Height mm (B)	Colour
50026002	Back profile 28	280	zn
50026004	Back profile 42	420	zn
50026005	Back profile 56	560	zn
50026011	Back profile 70	700	zn
50026006	Back profile 84	840	zn
50026003	Back profile 98	980	zn
50026007	Back profile 112	1120	zn
50026008	Back profile 140	1400	zn
50026009	Back profile 168	1680	zn
50026010	Back profile 196	1960	zn

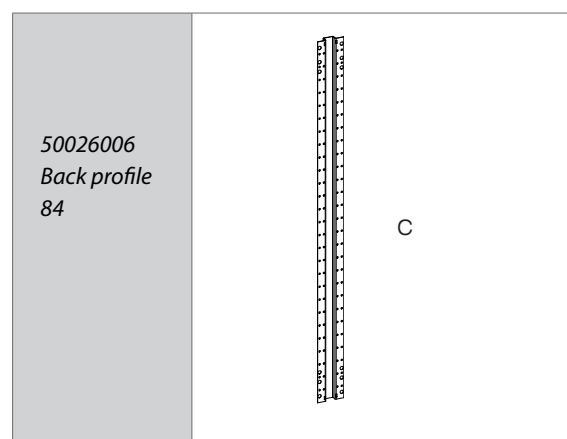

1.7 End- and intermediate supports, horizontal

1. End support

Code	Description	Depth mm (A)	Colour
50526030	End support 8	80	zn
50026031	End support 16	160	zn
50026032	End support 25	250	zn
50026033	End support 32	320	zn

2. Intermediate support

Code	Description	Depth mm (A)	Colour
50526070	Intermediate support 8	80	zn
50026071	Intermediate support 16	160	zn
50026072	Intermediate support 25	250	zn
50026073	Intermediate support 32	320	zn

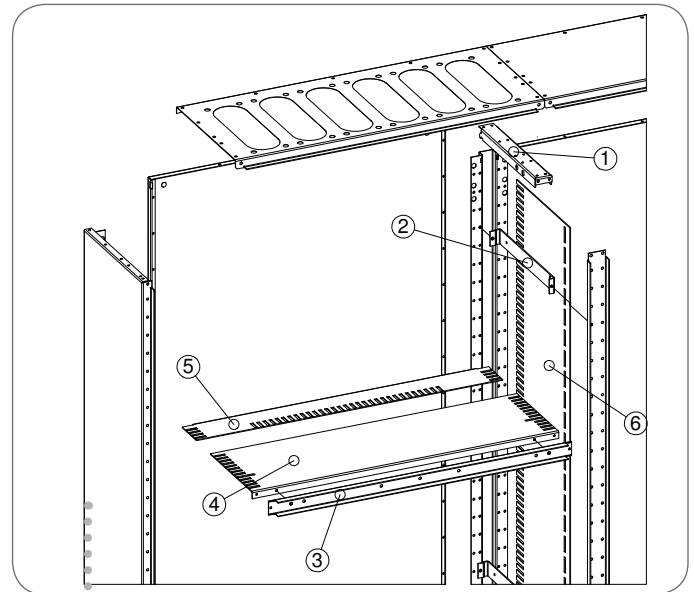

1. End support
2. Intermediate support
3. Horizontal intermediate profile
4. Front drip cover plate
5. Rear drip cover plate
6. Divider

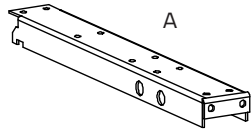
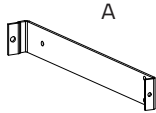
50026032 End support 25	
50026072 Intermediate support 25	

5. Rear drip cover pl.

Code	Description	Depth mm (A)	Height mm (B)	Material
50027061	Rear drip cover pl. 30- 8	80	300	PVC
50027062	Rear drip cover pl. 45- 8	80	450	PVC
50027063	Rear drip cover pl. 60- 8	80	600	PVC
50027064	Rear drip cover pl. 75- 8	80	750	PVC

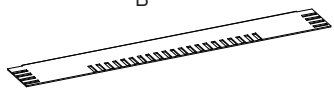
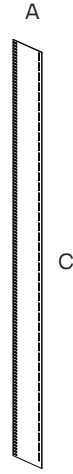
50027062 Rear drip cover pl. 45- 8	
50026092 Divider 25-200	

6. Divider

Code	Description	Depth mm (A)	Height mm (C)	Material
50026090	Divider 8-200	80	2000	PVC
50026091	Divider 16-200	160	2000	PVC
50026092	Divider 25-200	250	2000	PVC
50026093	Divider 32-200	320	2000	PVC

1.8 Busbar insulators and busbar insulator holders

1. Busbar insulator

Code	Description	Material
50081020	Busbar insulator MFBH W10/20 (8+8)	PC
50081022	Busbar insulator MFBH W30(8)	PC
50081024	Busbar insulator MFBH W40(8)	PC
50081026	Busbar insulator MFBH W50(8)	PC
50026042	Busbar insulator KuteW15x3	PC

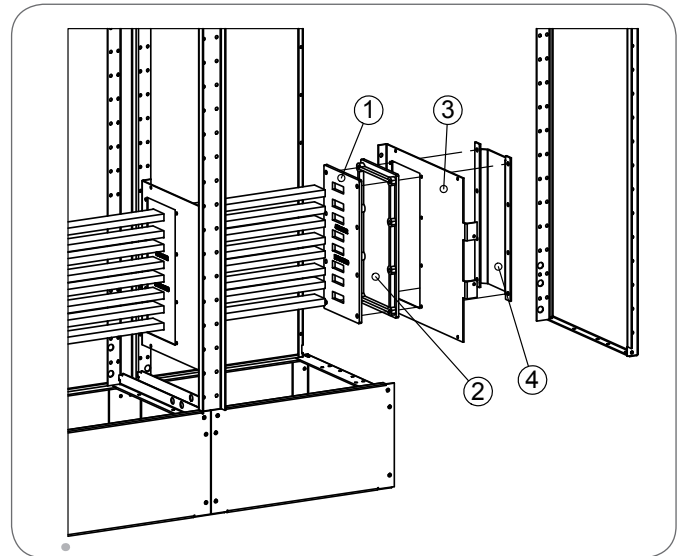
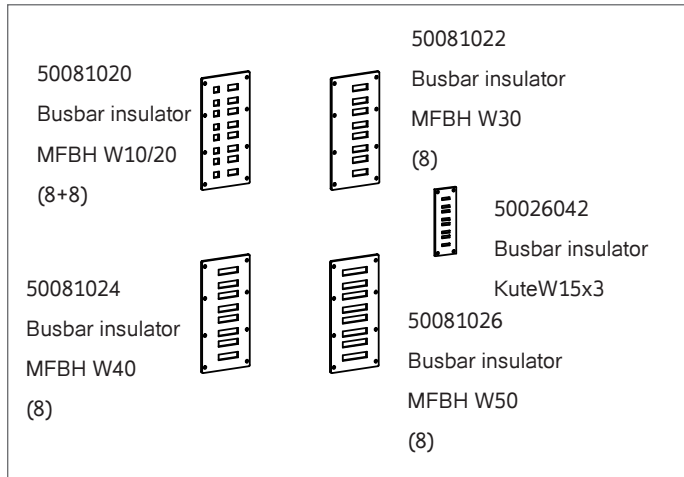

1. Bus-bar insulator
2. Bus-bar insulator end
3. Bus-bar insulator holder
4. End arc barrier

2. Busbar insulator end

Code	Description	Material
50081052	Busbar insulator end MFEBH 210	PC
50081050	Busbar insulator end MFEBH 70	PC

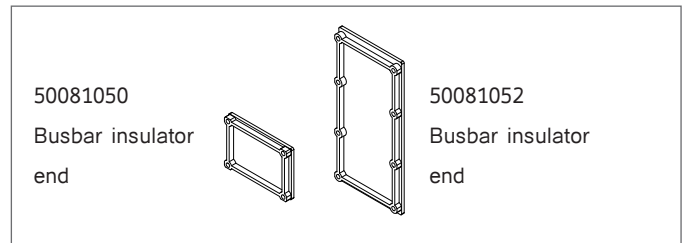

3. Bb. insulator holder

Code	Description	Depth mm (A)	Colour
50026050	Bb. insulator holder 16C	160	zn
50026051	Bb. insulator holder 25C	250	zn
50026043	Bb. insulator holder 32C	320	zn
50026052	Bb. insulator holder 16B	160	zn
50026053	Bb. insulator holder 32AL	320	zn
50026054	Bb. insulator holder 16AL	160	zn
50026055	Bb. insulator holder 25AL	250	zn

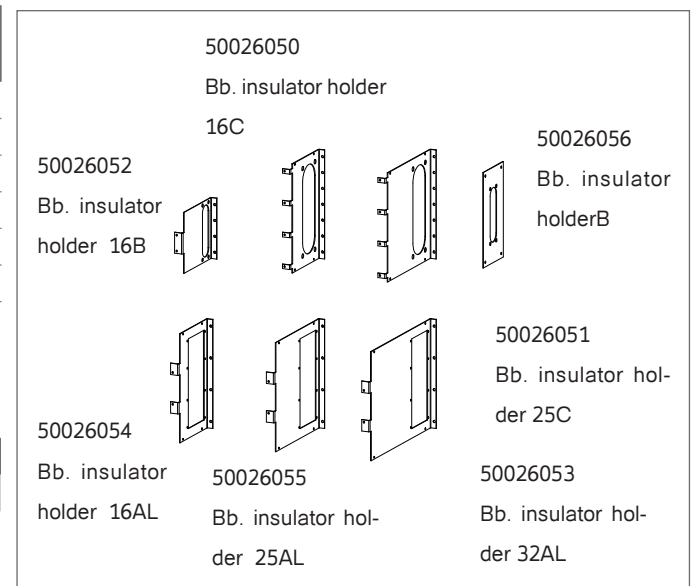

4. End arc barrier

Code	Description	Colour
50028294	End arc barrier/38	zn

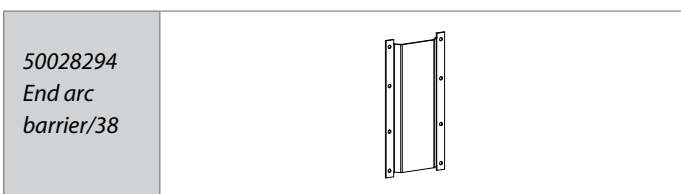

1.9. Special parts

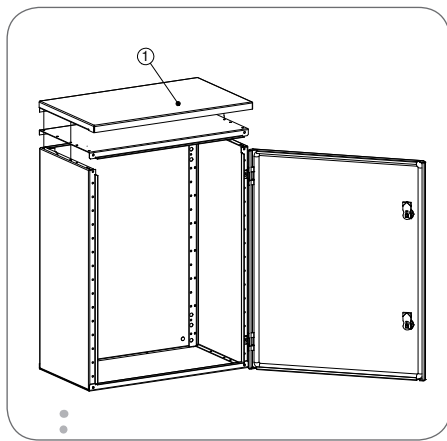

1. Rain cover

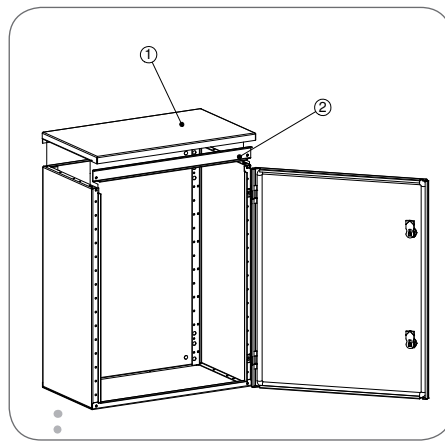

1. Rain cover
2. Sealing bead

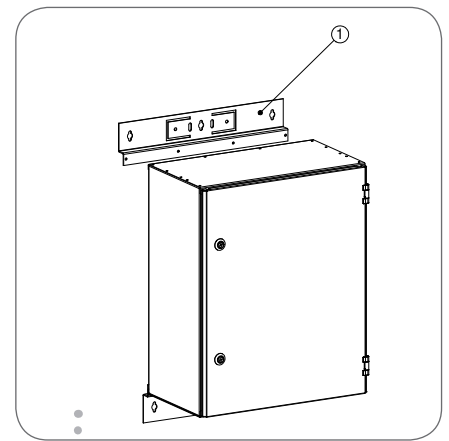

1. Pylon mounting bracket

1. Rain cover

Code	Description	Depth mm (A)	Width mm (B)	Colour
50529070-2	Rain cover 16-30	160	300	RAL7035
50529071-2	Rain cover 16-45	160	450	RAL7035
50529072-2	Rain cover 16-60	160	600	RAL7035
50529073-2	Rain cover 25-30	250	300	RAL7035
50529074-2	Rain cover 25-45	250	450	RAL7035
50529075-2	Rain cover 25-60	250	600	RAL7035
50529076-2	Rain cover 32-30	320	300	RAL7035
50529077-2	Rain cover 32-45	320	450	RAL7035
50529078-2	Rain cover 32-60	320	600	RAL7035

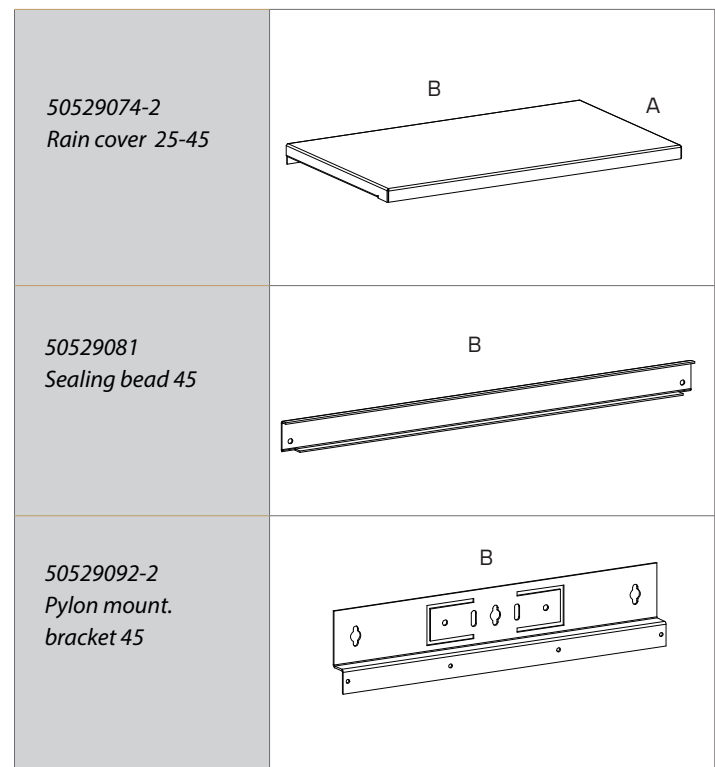

2. Sealing beads

Code	Description	Width mm (B)	Height mm (C)	Colour
50529080-2	Sealing bead 30	300		RAL7035
50529081-2	Sealing bead 45	450		RAL7035
50529082-2	Sealing bead 60	600		RAL7035

3. Pylon mount. bracket

Code	Description	Width mm (B)	Height mm (C)	Colour
50529091-2	Pylon mount. bracket 30	300		RAL7035
50529092-2	Pylon mount. bracket 45	450		RAL7035
50529093-2	Pylon mount. bracket 60	600		RAL7035

2. CELL STRUCTURE

2.1 Base components

1. Base end plate

Code	Description	Depth mm (A)	Height mm (B)	Colour
50028070	Base end plate	500	140	zn
50028107	Base end plate 40	500	40	zn

2. Base dividers

Code	Description	Depth mm (A)	Height mm (B)	Colour
50028071	Base divider	500	140	zn
50028108	Base divider 40	500	40	zn

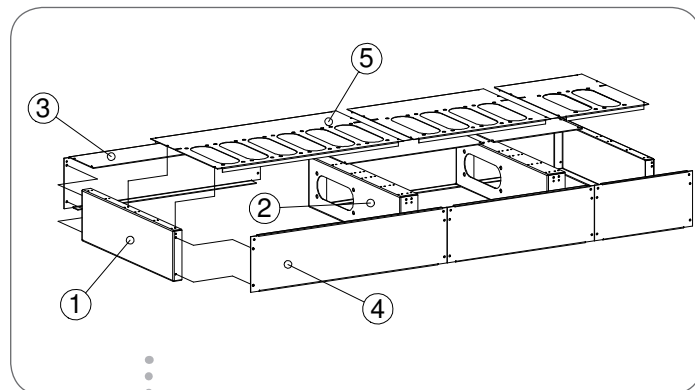

1. Base end plate
2. Base divider
3. Base back plate
4. Base front plate
5. Base bottom plate

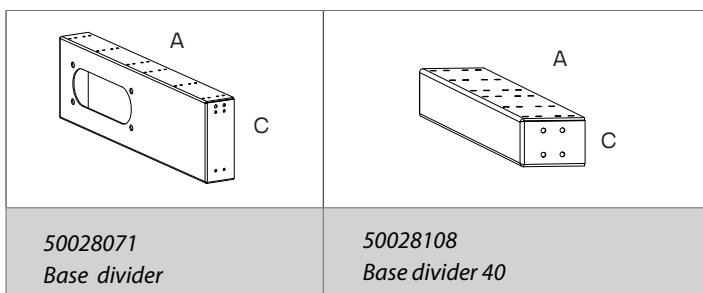
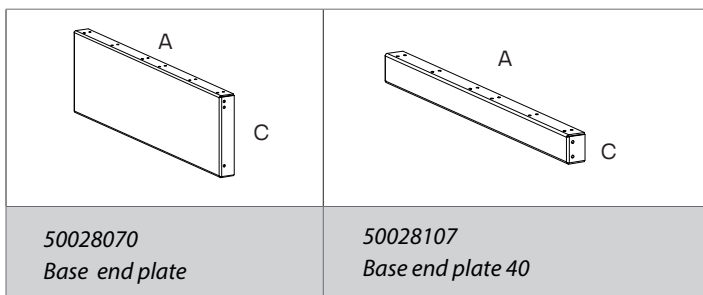

3. Base back plates

Code	Description	Width mm (B)	Height mm (C)	Colour
50028039	Base back plate 20	200	140	zn
50028040	Base back plate 30	300	140	zn
50028041	Base back plate 45	450	140	zn
50028042	Base back plate 60	600	140	zn
50028043	Base back plate 75	750	140	zn
50028116	Base back plate 204	200	40	zn
50028104	Base back plate 304	300	40	zn
50028105	Base back plate 454	450	40	zn
50028106	Base back plate 604	600	40	zn
50028110	Base back plate 754	750	40	zn

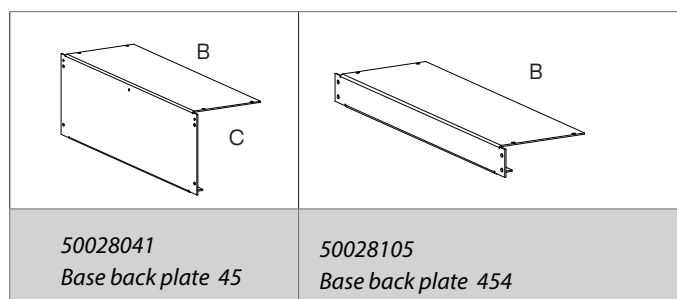

4. Base front plates

Code	Description	Width mm (B)	Height mm (C)	Väri
50528064	Base front plate 20	200	140	zn
50528065	Base front plate 30	300	140	zn
50528066	Base front plate 45	450	140	zn
50528067	Base front plate 60	600	140	zn
50528068	Base front plate 75	750	140	zn
50528070	Base front plate 30 IP30	300	140	zn
50528071	Base front plate 45 IP30	450	140	zn
50528072	Base front plate 60 IP30	600	140	zn
50528073	Base front plate 75 IP30	750	140	zn
50528115	Base front plate 204	200	40	zn
50528101	Base front plate 304	300	40	zn
50528102	Base front plate 454	450	40	zn
50528103	Base front plate 604	600	40	zn
50528109	Base front plate 754	750	40	zn

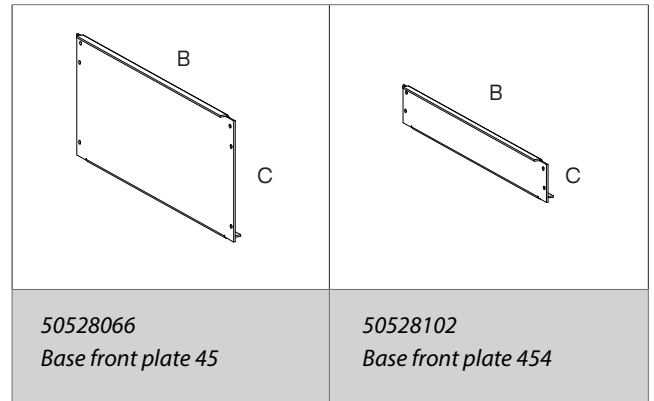

5. Sokkelin Bottom plate t

Code	Description	Depth mm (A)	Width mm (B)	Colour
50028044	Bottom plate 20- 35 2C	356	200	zn
50028045	Bottom plate 30- 35 2C	356	300	zn
50028046	Bottom plate 45- 35 4C	356	450	zn
50028047	Bottom plate 60- 35 6C	356	600	zn
50028048	Bottom plate 75- 35 6C	356	750	zn

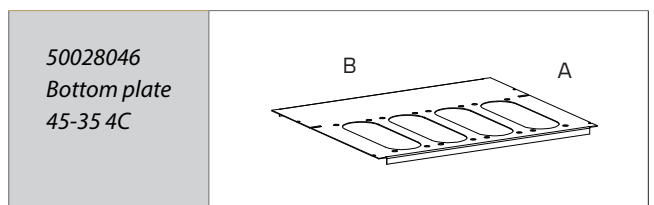

2.2. Frame plates, divider and back plates

1. Frame plates

Code	Description	Depth mm (A)	Height mm (C)	Colour
50028205	Frame plate 26-168U	260	1680	zn
50028005	Frame plate 26-196U	260	1960	zn
50028006	Frame plate 26-196P	260	1960	zn

2. End support

Code	Description	Depth mm (A)	Colour
50026032	End support 25	250	zn

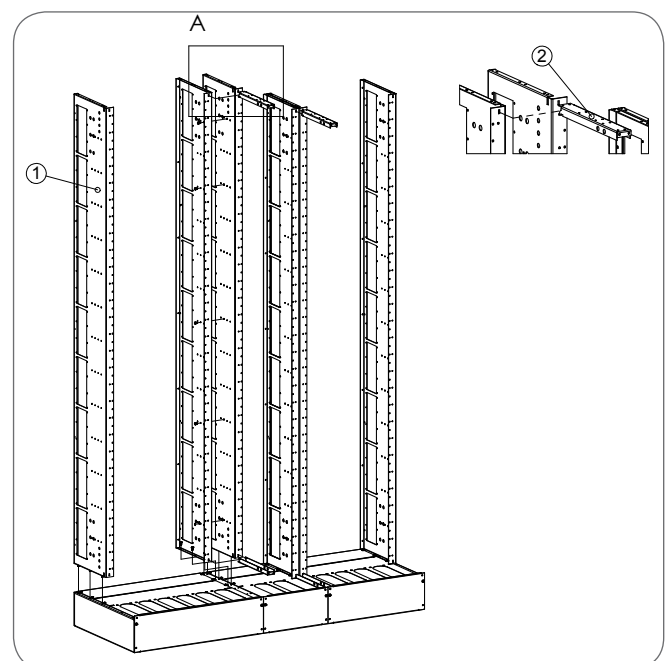
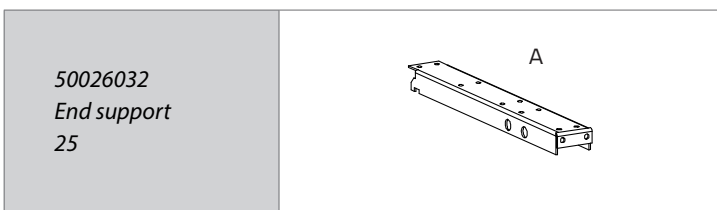

- 1. Frame plate
- 2. End support

3. Dividers

Code	Description	Depth mm (A)	Height mm (C)	Colour
50028089	Divider 16-196	160	1960	zn
50028166	Divider 25-168 with square holes	250	1680	zn
50028165	Divider 25-168 plain	250	1680	zn
50028090	Divider 25-196	250	1960	zn
50028166	Divider 25-196 plain	250	1960	zn
50028091	Divider 25-168-2	250	1680	zn
50028092	Divider 25-196-2	250	1960	zn
50028093	Divider 32-196	320	1960	zn

4. Back plates

Code	Description	Width mm (B)	Height mm (C)	Väri
50028007	Back plate 20-168	200	1680	zn
50029235	Back plate 30-168	300	1680	zn
50029236	Back plate 45-168	450	1680	zn
50029237	Back plate 60-168	600	1680	zn
50029238	Back plate 75-168	750	1680	zn
50028009	Back plate 20-196	200	1960	zn
50028010	Back plate 30-196	300	1960	zn
50028011	Back plate 45-196	450	1960	zn
50028012	Back plate 60-196	600	1960	zn
50028013	Back plate 75-196	750	1960	zn

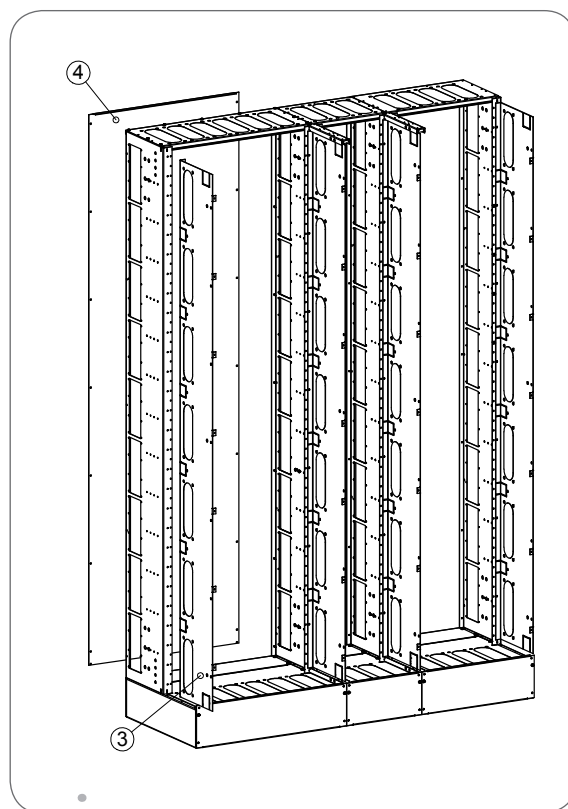

- 1. Divider
- 2. Back plate

Back plates with ventilation opening

Code	Description	Width mm (B)	Height mm (C)	Väri
50028008	Back plate with ventilation openings 30-168	300	1680	zn
50028014	Back plate with ventilation openings 45-168	450	1680	zn
50028015	Back plate with ventilation openings 60-168	600	1680	zn
50028016	Back plate with ventilation openings 75-168	750	1680	zn
50029231	Back plate with ventilation openings 30-196	300	1960	zn
50029232	Back plate with ventilation openings 45-196	450	1960	zn
50029233	Back plate with ventilation openings 60-196	600	1960	zn
50029234	Back plate with ventilation openings 75-196	750	1960	zn

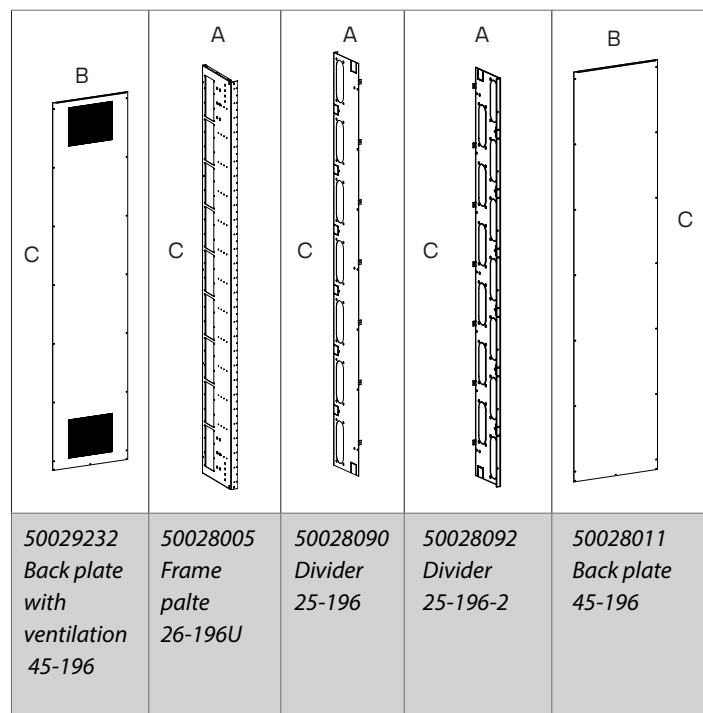

2.3. Side- and end plates

1. Side plates for cell centre

Code	Description	Depth mm (A)	Height mm (C)	Colour
50528201-2	Side plate for cell centre 50-168	500	1680	RAL7035
50528001-2	Side plate for cell centre 50-196	500	1960	RAL7035
50528001R-2	Side plate for cell centre 50- 196 IP20	500	1960	RAL7035

2. End plates for cell

Code	Description	Depth mm (A)	Width mm (B)	Colour
50528160-2	End plate for cell30-50 C	500	300	RAL7035
50528161-2	End plate for cell45-50 C	500	450	RAL7035
50528162-2	End plate for cell60-50 C	500	600	RAL7035
50528165-2	End plate for cell45-50 A	500	450	RAL7035
50528166-2	End plates for cell60-50 A	500	600	RAL7035
50528167-2	End plates for cell75-50 A	500	750	RAL7035

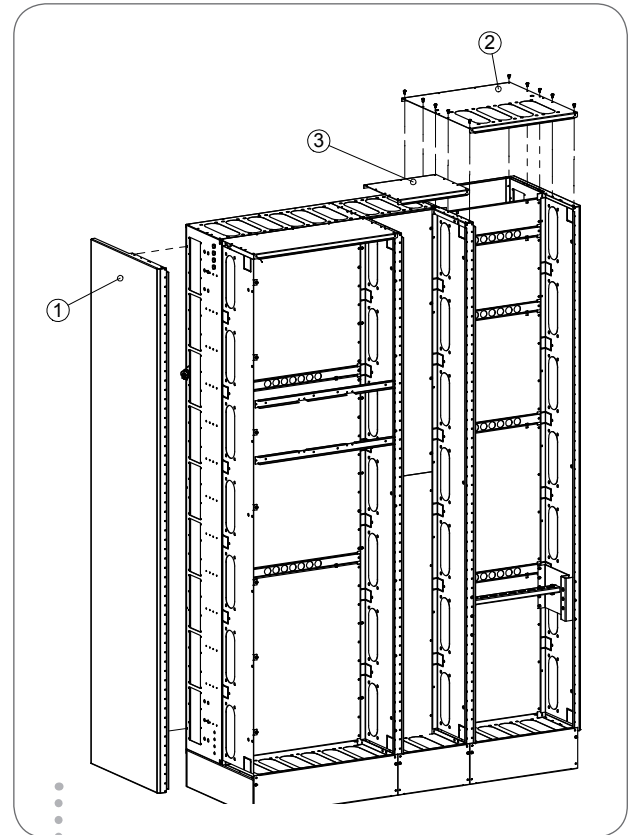

1. Side plate for cell centre
2. End plate for cell centre
3. End plate for two piece roof

<p>50528161-2 End plate for cell</p>	<p>50528165-2 End plate for cell60-50A</p>	<p>50528001-2 Side plate for cell centre 50-168</p>

Special end plates

Code	Description	Depth mm (A)	Width mm (B)	Colour
50529171-2	Special end plates 30-25 E	250	300	RAL7035
50529172-2	Special end plates 45-25 E	250	450	RAL7035
50529173-2	Special end plates 60-25 E	250	600	RAL7035
50529181-2	Special end plates 30-25 EP	250	300	RAL7035
50529182-2	Special end plates 45-25 EP	250	450	RAL7035
50529183-2	Special end plates 60-25 EP	250	600	RAL7035
50529184-2	Special end plates 60-25 EP2	250	600	RAL7035

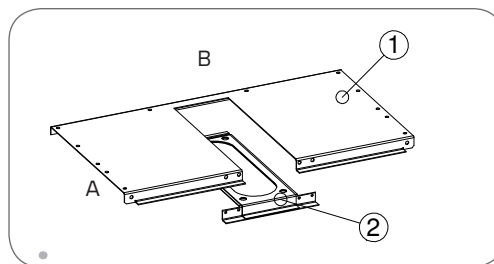

1. 50529172-2 Special end plates 45-25 E
2. 50529170-2 Feedthrough plate for special end

3. End plates for two piece roof

Code	Description	Depth mm (A)	Width mm (B)	Colour
50522999-2	End plate 20-25	250	200	RAL7035
50523000-2	End plate 20-25 C	250	200	RAL7035
50523005-2	End plate 30-25	250	300	RAL7035
50523039-2	End plate 30-25 2C	250	300	RAL7035
50523017-2	End plate 45-25	250	450	RAL7035
50523018-2	End plate 45-25 C	250	450	RAL7035
50523040-2	End plate 45-25 4C	250	450	RAL7035
50523025-2	End plate 60-25	250	600	RAL7035
50523041-2	End plate 60-25 4C	250	600	RAL7035
50523026-2	End plate 60-25 6C	250	600	RAL7035
50523006-2	End plate 30-25 3C	250	300	RAL7035
50523031-2	End plate 75-25	250	750	RAL7035
50523032-2	End plate 75-25 C	250	750	RAL7035
50523042-2	End plate 75-25 6C	250	750	RAL7035

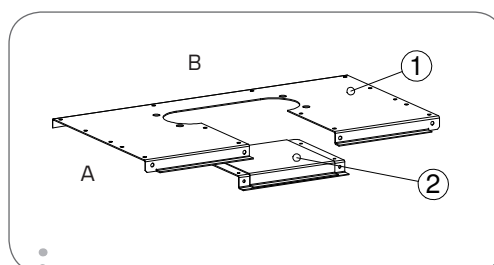

1. 50529182-2 Special end plates 45-25 EP
2. 50529180-2 Covering plate for special end

2.4. Roof plates and busbar protective covers

1. Roof plates

Code	Description	Width mm (B)	Colour
50528130-2	Roof plate 30	300	RAL7035
50528131-2	Roof plate 45	450	RAL7035
50528132-2	Roof plate 60	600	RAL7035

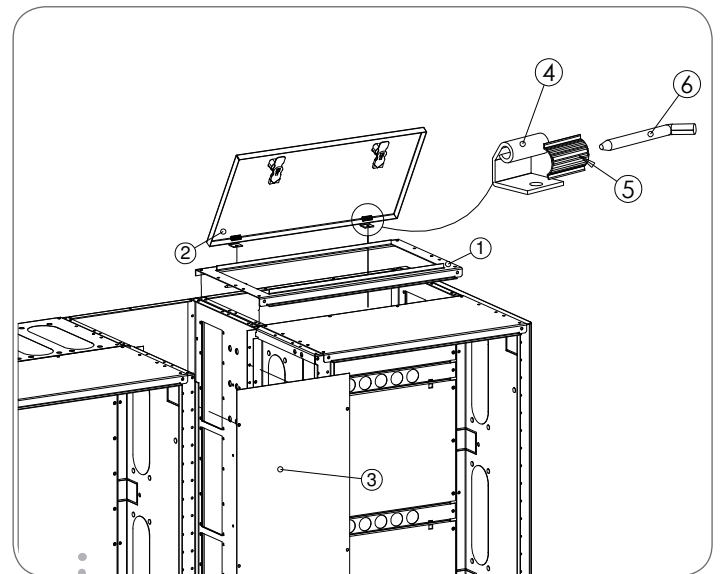
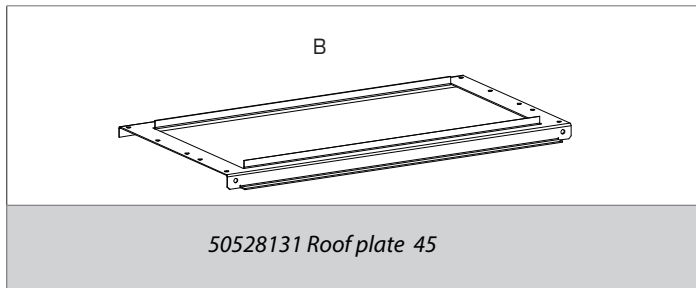

2. Roof access door

Code	Description	Width mm (B)	Colour
50528120-2	Roof access door 30	300	RAL7035
50528121-2	Roof access door 45	450	RAL7035
50528122-2	Roof access door 60	600	RAL7035
50528123-2	Roof access door 75	750	RAL7035

1. Roof plate
2. Roof access door
3. Busbar protective cover
4. Hinge
5. Hinge flap
6. Hinge pin

3. Busbar protective covers

Code	Description	Width mm (B)	Height mm (C)	Väri
50028030	Busbar protective cover 20- 98	200	980	zn
50028031	Busbar protective cover 30- 98	300	980	zn
50028032	Busbar protective cover 45- 98	450	980	zn
50028033	Busbar protective cover 60- 98	600	980	zn
50028035	Busbar protective cover 75- 98	750	980	zn

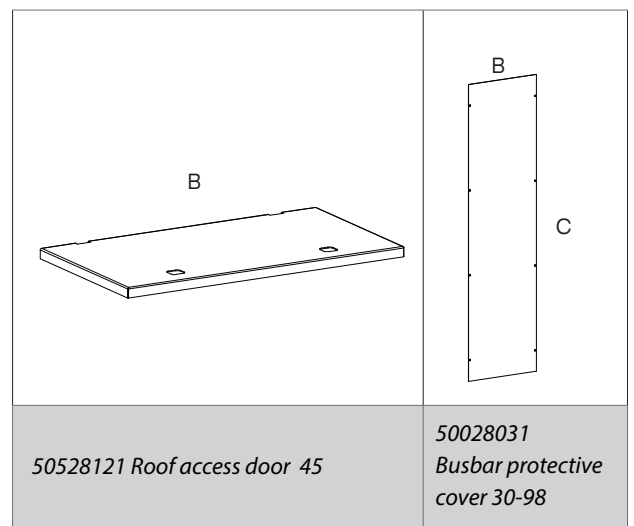

2.5. Lifting components

1. Lifting bracket

Code	Description	Colour
50028095	Lifting bracket M12	zn
50028098	Lifting bracket M16	zn

2. Lifting loop

Code	Description	Colour
50028094	Lifting loop M12	zn

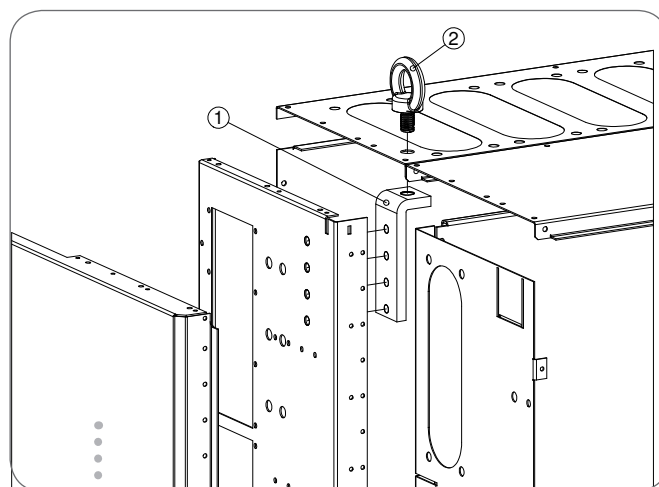
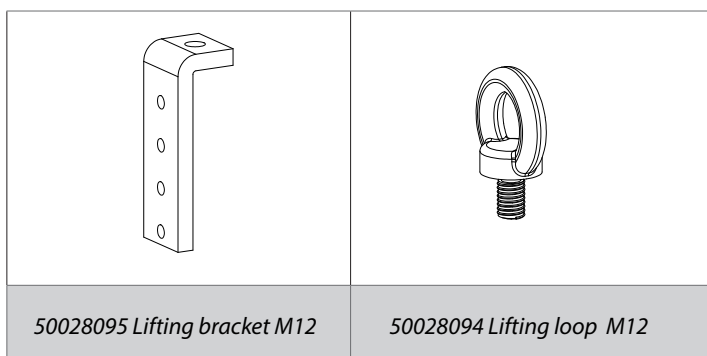

- 1. Lifting bracket
- 2. Lifting loop

2.6. Heavy component's fastening

1. Heavy-duty hanger

Code	Description	Colour
50028150	Heavy-duty hanger	zn

2. Heavy-duty holder

Code	Description	Colour
50028151	Heavy-duty holder	zn

3. C-rail

Code	Description	Width mm (B)	Colour
50059079	C-rail 450	450	zn
50059080	C-rail 600	600	zn
50059081	C-rail 750	750	zn

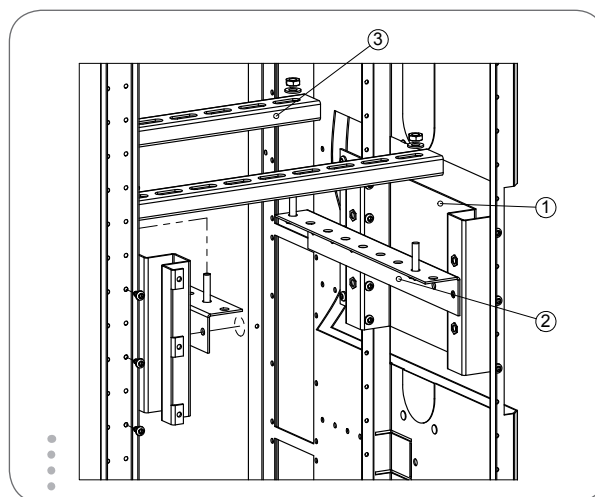

- 1. Heavy-duty hanger
- 2. Heavy-duty holder

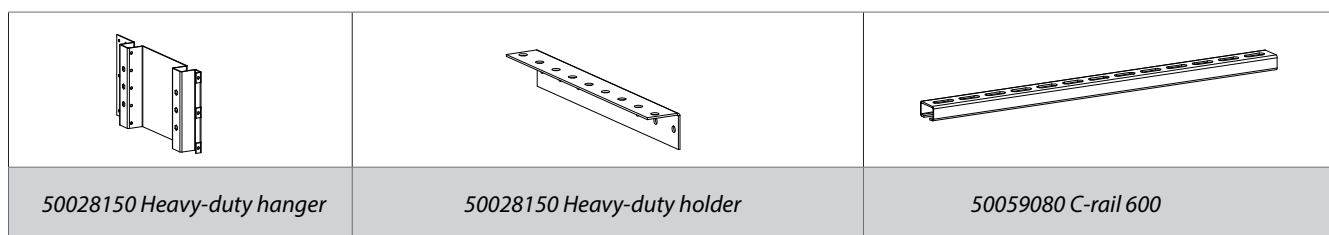

2.7. Drip cover plate, metal

Code	Description	Width mm (B)	Colour
50027065	Drip cover plate, metal	300	zn
50027066	Drip cover plate, metal	450	zn
50027067	Drip cover plate, metal	600	zn
50027068	Drip cover plate, metal	750	zn

2.8. Parts for transportation break

1. Contin. vertical profile

Code	Description	Height mm (C)	Colour
50528021	Contin. vertical profile 168 pair	1680	zn
50528020	Contin. vertical profile 196 pair	1960	zn
50528020R	Contin. vertical profile 196 IP20 pair	1960	zn

2. Assembly profile

Code	Description	Height mm (C)	Colour
50028025	Assembly profile 188	1880	zn

3. Cover plate

Code	Description	Depth mm (A)	Height mm (C)	Colour
50028034	Cover plate	100	1468	zn

4. Extension end support, pair

Code	Description	Depth mm (A)	Colour
50028060	Extension end support, pair 25	250	zn

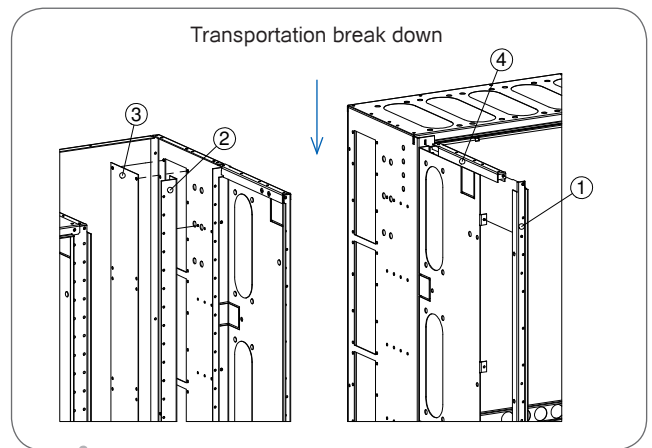

1. Contin. vertical profile
2. Assembly profile
3. Cover plate
4. Extension end support, pair

50028020 Jatkoetu- profiili, pari 196	50028025 Assembly profile 188	50028034 Cover plate	50028060 Extension end support, pair pari 25

2.9. Busbar insulators and -holders

1. Vertical bus holders, enclosure-/cell structure

Code	Description	Width mm (B)	Colour
50028050	Vertical Bus holder 30	300	zn
50028051	Vertical Bus holder 45	450	zn
50028052	Vertical Bus holder 60	600	zn
50028053	Vertical Bus holder 75	750	zn

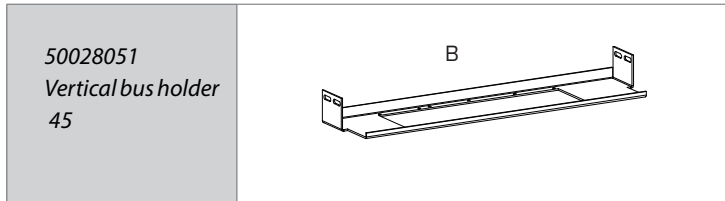

2. Busbar insulator

Code	Description	Material
50081006	Busbar insulatorMFBH H50 (2)	PC
50081010	Busbar insulatorMFBH H10-20 (6+6)	PC
50081012	Busbar insulatorMFBH H30 (6)	PC
50081014	Busbar insulatorMFBH H40 (6)	PC
50081016	Busbar insulatorMFBH H50 (6)	PC
50081000	Busbar insulatorMFBH h10-20 (2+2)	PC
50081002	Busbar insulatorh30 (2)	PC
50081004	Busbar insulatorh40 (2)	PC
50028084	Bb. insul. for serial circuit Kute30 JV	PC
50028085	Bb. insul. for serial circuit Kute40 JV	PC
50028086	Bb. insul. for serial circuit Kute50 JV	PC

3. Busbar insulator end

Code	Description	Material
50081052	Busbar insulator end MFEHBH 210	PC
50081050	Busbar insulator end MFEHBH 70	PC
50028087	Bb. insul. end for serial circuit Kutep JV	PC

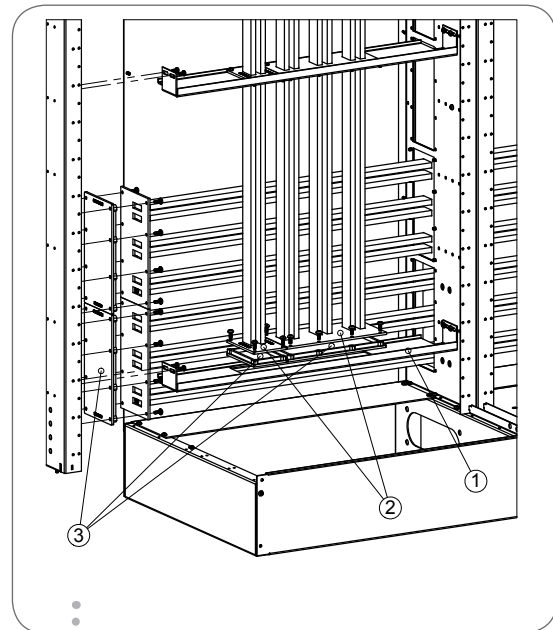
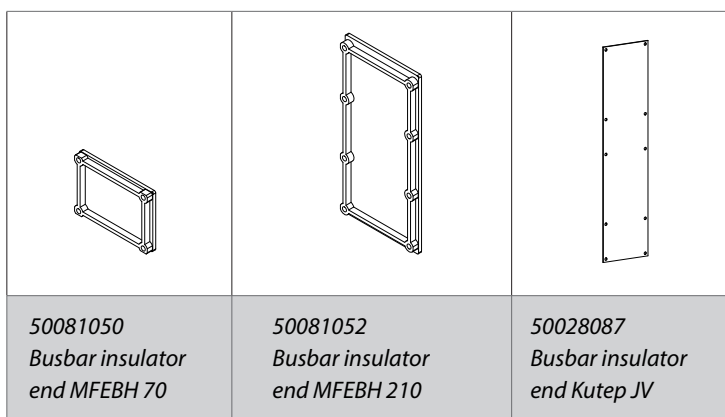

1. Vertical Bus holder
2. Bus-bar insulator
3. Bus-bar insulator end

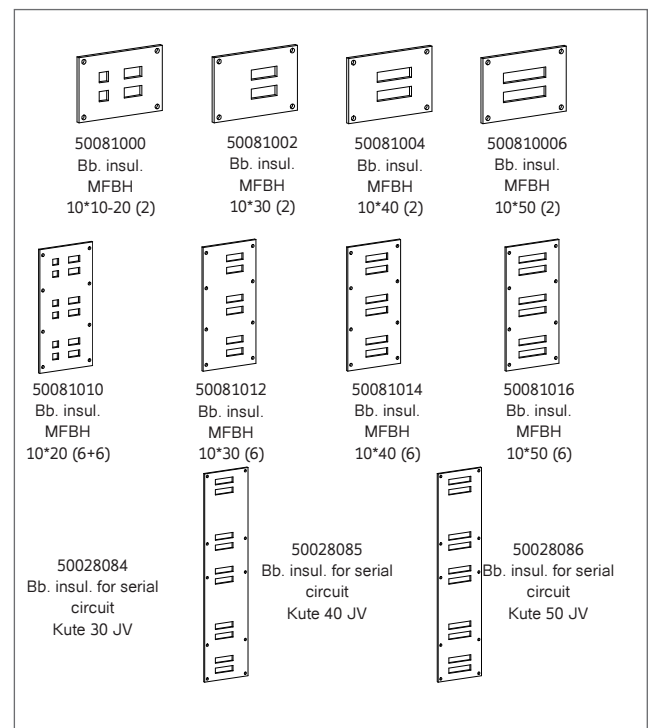

2.10. Corner cell structure

1. Corner front plate of the base

Code	Description	Colour
50529201	Corner front plate of the base	zn

2. Corner roof

Code	Description	Colour
50529202-2	Corner roof	RAL7035

3. Corner door

Code	Description	Height mm (C)	Colour
50529206-2	Corner door 168	1680	RAL7035
50529203-2	Corner door 196	1960	RAL7035

4. Corner back plates

Code	Description	Height mm (C)	Colour
50529205	Corner back plate 168	1680	zn
50529204	Corner back plate 196	1960	zn

5. Back plates

Code	Description	Colour
50029238	Back plate 75-168	zn
50028013	Back plate 75-196	zn

6. End plates

Code	Description	Colour
50523025-2	End plates 60-25	RAL7035

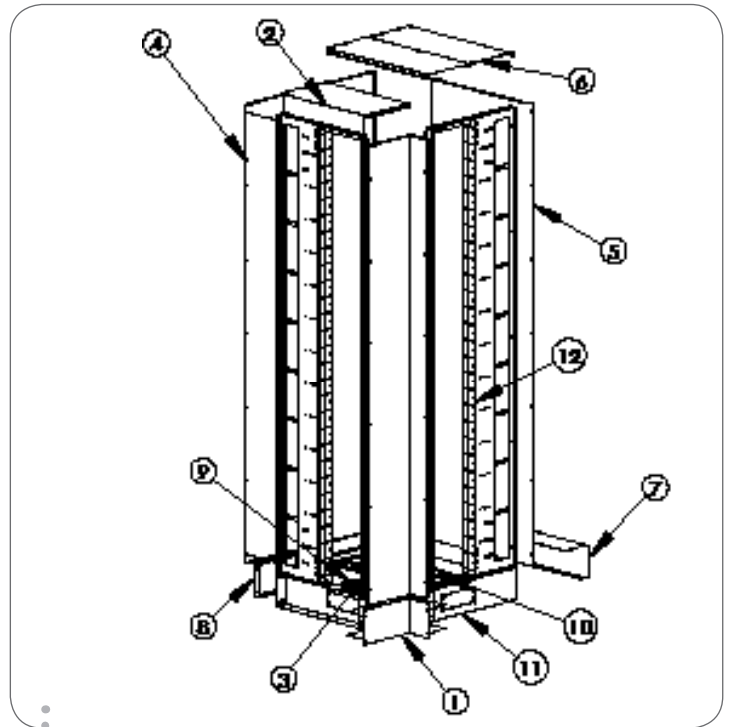

- 1. Corner front plate of base
- 2. Corner roof
- 3. Corner door
- 4. Corner back plate
- 5. Back plate
- 6. End plate
- 7. Base back plate
- 8. End of base 25
- 9. Bottom plate
- 10. Intermediate base plate 140
- 11. Frame plate
- 12. Base end plate

<p>50529201 Corner front plate of the base</p>	<p>50529202 Corner roof</p>	<p>50529203 Corner door 196</p>	<p>50529204 Corner back plate 196</p>

7. Base back plate

Code	Description	Colour
50028042	Base back plate 60	zn

8. End of base

Code	Description	Colour
50028070	End of base	zn

9. Bottom plate

Code	Description	Colour
50028047	Bottom plate 60- 35 6C	zn

10. Intermediate base plate

Code	Description	Colour
50028071	Intermediate base plate	zn

11. Frame plate

Code	Description	Colour
50028071	Frame plate 26-168U	zn
50028005	Frame plate 26-196U	zn

2.1.1. Drip cover plate, metal

Koodi	Nimike	Leveys mm (B)	Väri
50027065	Drip cover plate, metal	300	zn
50027066	Drip cover plate, metal	450	zn
50027067	Drip cover plate, metal	600	zn
50027068	Drip cover plate, metal	750	zn

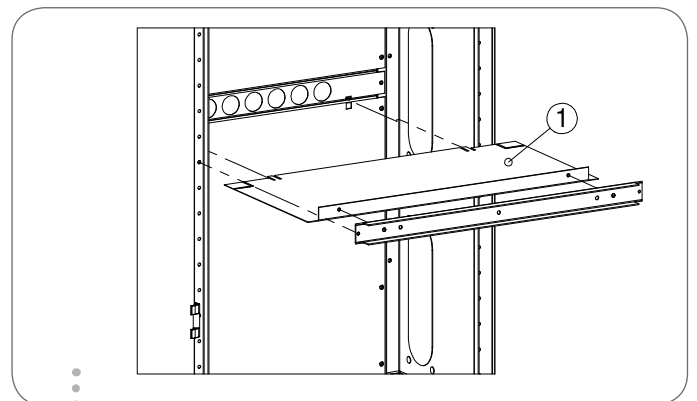
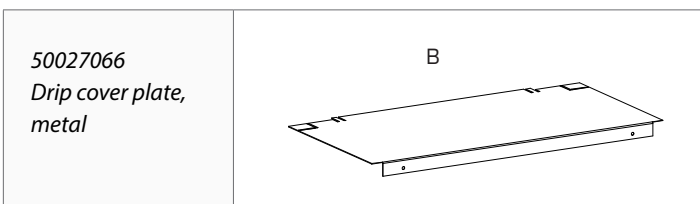

1. Drip cover plate, metal

MATCHING PARTS - PART LIST

1.E-SERIE/E-NFS	3
1.1 Mounting plates	3
1.2 Horizontal intermediate profiles E and E-NFS	5
1.3 Mounting plate fastening rail	5
2. F-SERIE/F-NBS/S-SERIE	6
2.1 Covers	6
2.1.2 Meter covers	7
2.1.3 Meter cover side plate	7
2.1.4 Dividing wall	7
2.1.5 Cover hinge	7
2.2 Light doors	10
2.3 Cover door system, enclosure system	12
2.4 Mounting plates, f-serie enclosure-/cell structure	14
2.5 Lowered mounting plate, cell structure	15
2.6 Horizontal intermediate profiles and feedthrough bead	15
2.7 Front drip cover plates, enclosure	16
2.8 Fastening parts, enclosure and F-series cell-centre	17
2.8.1 Foot bolks for enclosures	19
2.9 Special parts, enclosure	20
3. MATCHING PARTS	23
3.1 Doors	23
3.1.1 Meter doors	27
3.1.2 1-Latch doors	27
3.1.3 Covers	27
COVERS	29
3.2 Intermediate covers and cover hinges	30
INTERMEDIATE COVERS	33
3.3 Touch- and finger screens	34
FINGER SCREENS	38
3.4 Elevation profiles	39
3.5 Special parts	40
3.6 Accessories	42