

## Centech Overspenningsvern B12.5V/275-S/4P

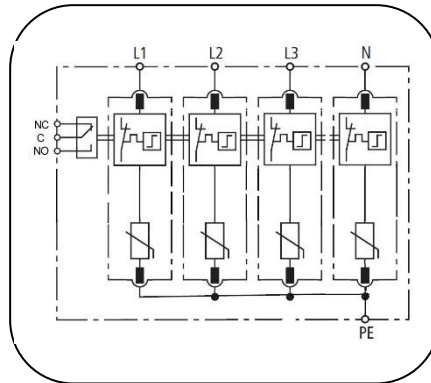

Basic circuit diagram

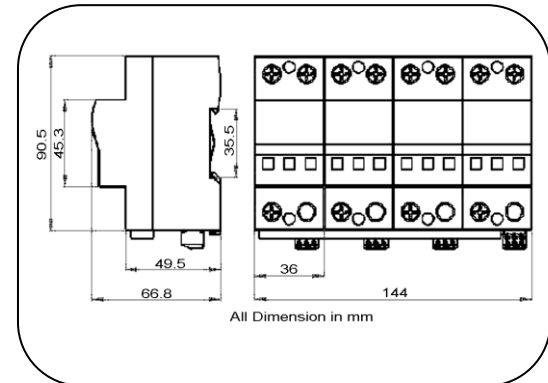

Dimension drawing

Overspenningsvern Type 1+2, designet for beskyttelse mot overspenninger i lavspent strømforsyningsystemer. Kan være et fornuftig valg ved f.eks luftledningsnett, og andre steder der man ønsker bedre beskyttelse mot atmosfæriske overspenninger enn det et vanlig Type-2 vern har.

- Type I+II / B+C overspenningsvern i samsvar med IEC61643-11 og UL1449-4th.
- Høy strømkapasitet på 12,5kA 10/350 og I<sub>max</sub> 80kA 8/20.
- Sikker frakobling når varistor er ødelagt.
- Feilindikering med rødt indikasjonsflagg i vindu.
- Med signalkontakt, NO/NC.

Part No.	CV058056
In accordance with	IEC61643-11:2011; UL1449-4th
Category IEC/VDE	I+ II / B+C
Max. continuous operating voltage U <sub>c</sub>	275VAC/350VDC
Nominal discharge current(8/20) I <sub>n</sub>	12.5kA
Max. discharge current(8/20) I <sub>max</sub>	80kA
Lightning impulse current(10/350) I <sub>imp</sub>	12.5kA
Voltage protection level @I <sub>n</sub>	<1.2kV
Response time	≤25 ns
Follow current	No
Backup fuse(only required if not already provided in mains)	250A gL/gG
Operating temperature range	- 40°C ~ + 80°C
Cross-section of connection wire	Single-strand 35mm <sup>2</sup> ; multi-strand 25mm <sup>2</sup>
Mounting	35mm DIN-rail in accordance with EN 50022/DIN46277-3
Enclosure material	thermoplastic; extinguishing degree UL94 V-0
Degree of protection	IP20
Installation width	8 modules, DIN 43880
Thermal disconnecter	Internal red - failure
Remote alarm contact	Yes
<b>Additional data for Remote Alarm Contacts</b>	
Remote alarm contact type	Isolated Form C
Switching capability U <sub>n</sub> /I <sub>n</sub>	AC: 250V/0.5A DC: 250V/0.1A; 125V/0.2A; 75V/0.5A
Max. Size of connecting wire	Max. 1.5mm <sup>2</sup> (or # 16AWG)

Cenika AS

Industrigata 13, 3414 Lierstranda - Norge

Tlf.: 32 24 03 00 - Faks : 32 24 03 01 - Mail: post@cenika.no - WEB: www.cenika.no