



## SHT W

### PTC HEATERS, WIRE CONNECTION



Features	Unit	SHT15W	SHT25W	SHT50W
Heating Capacity*	W	15	25	50
Power supply	V/Hz	110-250V AC or DC		
Inrush current	A	2	2.5	3.5
Delayed fuse (advised)	A	4	4	6.3
Heating element type	-	PTC resistor, self regulating		
Electrical connection	-	Silicon cable, 2x0.5mm <sup>2</sup> , length 400mm		
Protection Class	-	Class II		
Protection degree EN60529	-	IP20		
Operating temperature	°C (°F)	-45/+70 (-49/+158)		
Storage temperature	°C (°F)	-45/+80 (-49/+176)		
Radiator	-	Extruded aluminium profile, anodized		
Mounting	-	Clip for mounting on DIN rail 35mm EN50022		
Installation position	-	Best efficiency in vertical position		
Dimensions HxWxD	mm	50x50x80	60x50x80	80x50x80
Cable length	mm	400	400	400
Weight (with packaging)	kg	0.2 (0.25)	0.24 (0.27)	0.28 (0.31)
Conformity/Certifications	-	CE		

\*at 20°C (68°F) ambient temperature

#### Accessories

Thermostat 0-60°C, NC contact	THR2
Double thermostat NC 0-60°C / NO 0-60°C	THR22
Hygrothermostat 0-60°C / 20-90%Rh	ETUH22
Hygrostat 10-90%Rh	MUH

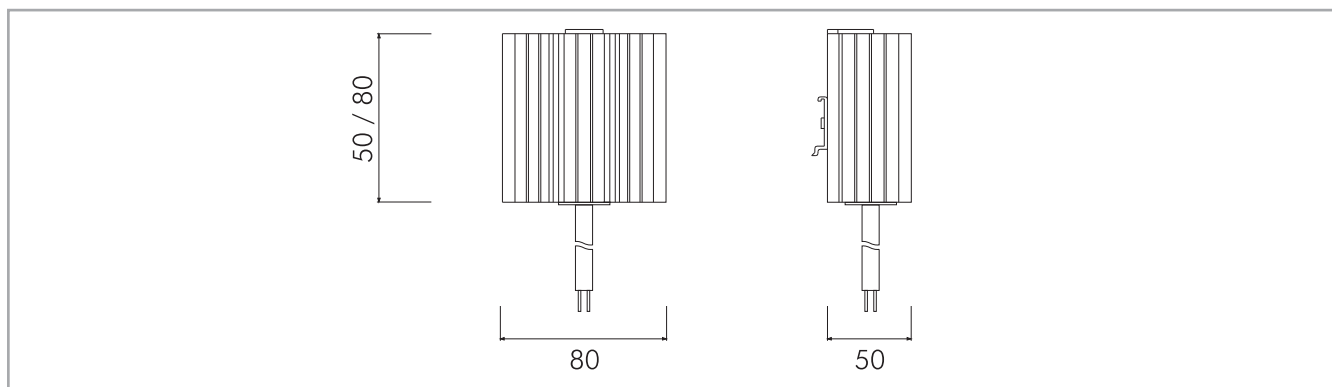

Specifications, values and drawings are subject to change without notice.